

Total solder points: 101
Difficulty level: *beginner* 1 2 3 4 5 *advanced*

ELECTRONIC WATCHDOG

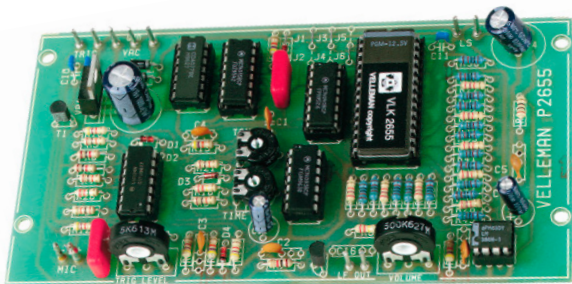

K2655

Listens and scares intruders with realistic barking.

Features:

- ☑ Very realistic simulation through the use of a random generator.
- ☑ Choice of two different dogs.
- ☑ Reacts to environment noise, with adjustable sensitivity.
- ☑ Trigger input to connect other detectors (photo-electric cell, motion detector, smoke detector, etc...).
- ☑ Connectable to more powerful amplifier.
- ☑ Complete with rectifier and voltage regulator.

Specifications:

- Power supply : 2x8V/0,5A transformer or 9 to 12VDC.
- Loudspeaker output (2W at 4 ohm).
- Supply current: standby: 75mA, when barking: max. 400mA.
- Dimensions: 142x75x30mm / (5,7x3x1,2").

1. Assembly (Skipping this can lead to troubles !)

Ok, so we have your attention. These hints will help you to make this project successful. Read them carefully.

1.1 Make sure you have the right tools:

- A good quality soldering iron (25-40W) with a small tip.
- Wipe it often on a wet sponge or cloth, to keep it clean; then apply solder to the tip, to give it a wet look. This is called 'thinning' and will protect the tip, and enables you to make good connections. When solder rolls off the tip, it needs cleaning.
- Thin raisin-core solder. Do not use any flux or grease.
- A diagonal cutter to trim excess wires. To avoid injury when cutting excess leads, hold the lead so they cannot fly towards the eyes.
- Needle nose pliers, for bending leads, or to hold components in place.
- Small blade and Phillips screwdrivers. A basic range is fine.

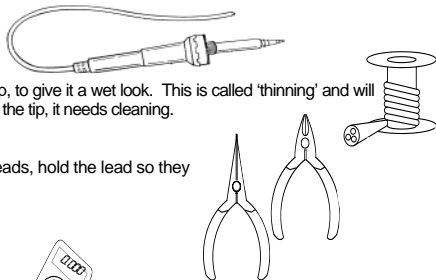

For some projects, a basic multi-meter is required, or might be handy



1.2 Assembly Hints :

- ⇒ Make sure the skill level matches your experience, to avoid disappointments.
 - ⇒ Follow the instructions carefully. Read and understand the entire step before you perform each operation.
 - ⇒ Perform the assembly in the correct order as stated in this manual
 - ⇒ Position all parts on the PCB (Printed Circuit Board) as shown on the drawings.
 - ⇒ Values on the circuit diagram are subject to changes.
 - ⇒ Values in this assembly guide are correct*
 - ⇒ Use the check-boxes to mark your progress.
 - ⇒ Please read the included information on safety and customer service
- * Typographical inaccuracies excluded. Always look for possible last minute manual updates, indicated as 'NOTE' on a separate leaflet.

1.3 Soldering Hints :

1- Mount the component against the PCB surface and carefully solder the leads

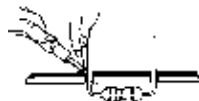

2- Make sure the solder joints are cone-shaped and shiny



3- Trim excess leads as close as possible to the solder joint



AXIAL COMPONENTS ARE TAPED IN THE CORRECT MOUNTING SEQUENCE !

REMOVE THEM FROM THE TAPE ONE AT A TIME !

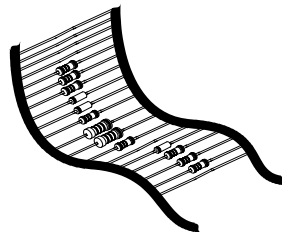

You will find the colour code for the resistances and the LEDs in the HALG (general manual) and on our website: <http://www.velleman.be/common/service.aspx>

1. Jumpers

- J1
- J3
- J6

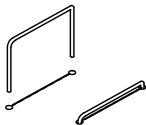

2. Diodes. Watch the polarity !

- D1 : 1N4148
- D2 : 1N4148
- D3 : 1N4148
- D4 : 1N4148
- D5 : 1N4148

- D6 : 1N4007
- D7 : 1N4007

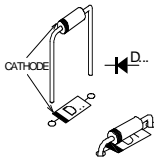

3. Resistors

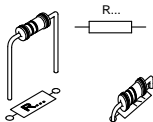

- R1 : 330 (3 - 3 - 1 - B)
- R2 : 10K (1 - 0 - 3 - B)
- R3 : 10K (1 - 0 - 3 - B)
- R4 : 10K (1 - 0 - 3 - B)
- R5 : 10K (1 - 0 - 3 - B)
- R6 : 220K (2 - 2 - 4 - B)
- R7 : 1K (1 - 0 - 2 - B)
- R8 : 1K (1 - 0 - 2 - B)
- R9 : 1K (1 - 0 - 2 - B)
- R10 : 4K7 (4 - 7 - 2 - B)
- R11 : 4K7 (4 - 7 - 2 - B)
- R12 : 4K7 (4 - 7 - 2 - B)
- R13 : 4K7 (4 - 7 - 2 - B)
- R14 : 47K (4 - 7 - 3 - B)
- R15 : 47K (4 - 7 - 3 - B)
- R16 : 47K (4 - 7 - 3 - B)
- R17 : 47K (4 - 7 - 3 - B)
- R18 : 220K (2 - 2 - 4 - B)
- R19 : 10 (1 - 0 - 0 - B)
- R20 : 2M2 (2 - 2 - 5 - B)

- R21 : 10K (1 - 0 - 3 - B)
- R22 : 2K7 (2 - 7 - 2 - B)
- R23 : 2K7 (2 - 7 - 2 - B)
- R24 : 2K7 (2 - 7 - 2 - B)
- R25 : 2K7 (2 - 7 - 2 - B)
- R26 : 2K7 (2 - 7 - 2 - B)
- R27 : 2K7 (2 - 7 - 2 - B)
- R28 : 2K7 (2 - 7 - 2 - B)
- R29 : 2K7 (2 - 7 - 2 - B)

4. Metal film resistors

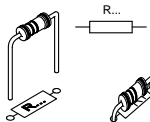

- R30 : 100K (1 - 0 - 0 - 3 - 1)
- R31 : 100K (1 - 0 - 0 - 3 - 2)
- R32 : 100K (1 - 0 - 0 - 3 - 1)
- R33 : 100K (1 - 0 - 0 - 3 - 1)
- R34 : 100K (1 - 0 - 0 - 3 - 1)

<input type="checkbox"/> R35 : 100K	(1-0-0-3-1)
<input type="checkbox"/> R36 : 100K	(1-0-0-3-2)
<input type="checkbox"/> R37 : 100K	(1-0-0-3-1)
<input type="checkbox"/> R38 : 100K	(1-0-0-3-2)
<input type="checkbox"/> R39 : 51K	(5-1-0-2-1)
<input type="checkbox"/> R40 : 51K	(5-1-0-2-2)
<input type="checkbox"/> R41 : 51K	(5-1-0-2-1)
<input type="checkbox"/> R42 : 51K	(5-1-0-2-2)
<input type="checkbox"/> R43 : 51K	(5-1-0-2-1)
<input type="checkbox"/> R44 : 51K	(5-1-0-2-2)
<input type="checkbox"/> R45 : 51K	(5-1-0-2-1)

5. IC sockets. Watch the position of the notch!

- IC1 : 14p
- IC2 : 14p
- IC3 : 16p
- IC4 : 28p
- IC5 : 16p
- IC6 : 14p
- IC7 : 8p

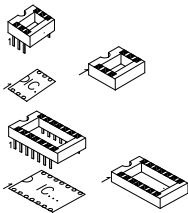

6. Capacitors.

- C1 : 100pF (101)
- C2 : 10nF (103)
- C3 : 10nF (103)
- C4 : 3,9nF (392)
- C5 : 47nF (473)
- C6 : 47nF (473)
- C9 : 100nF (104)
- C10 : 100nF (104)
- C11 : 100nF (104)

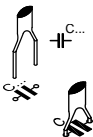

7. Resistor trimmers

- RV2 : 2M2 Time
- RV3 : 100K Tone

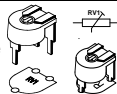

8. Transistors

- T1 : BC547
- T2 : BC557

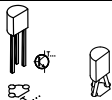

9. PCB tabs.

- A
 - GND
 - B
- } VAC
- +
 -
- } TRIG
- +
 -
- } MIC
- +
 -
- } LS

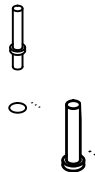

10. Capacitors

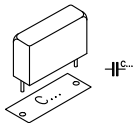

- C7 : 100nF / 250V
- C8 : 100nF / 250V

11. Electrolytic Capacitors. Watch the polarity !

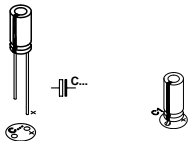

- C12 : 10 μ F / 35V
- C13 : 10 μ F / 35V
- C14 : 220 μ F / 16V
- C15 : 1000 μ F / 16V

12. Big trimmers.

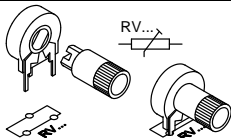

- RV1 : 4K7 TRIG level
- RV4 : 470K Volume

13. Voltage regulator

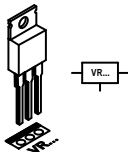

- VR1 : UA7805

14. IC's. Watch the position of the notch!

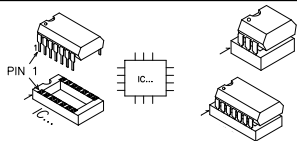

- IC1 : LM324 or eq.
- IC2 : CD4093 or eq.
- IC3 : CD4040 or eq.
- IC4 : VK2655

(programmed Eprom 2764C25)

- IC5 : CD4015 or eq.
- IC6 : CD4077 or eq.
- IC7 : LM386 or eq.

15. Microphone



MIC

Attention : the negative connection is the one closest to the earth lip of the microphone housing.

Solder them both together. The remaining pin is the positive connection. Twist the connection wires in order to avoid interferences and noise.

Tip : use screened cable (Screen connected to the negative should the connection be too long (0,5m or 2ft)).

16. CONNECTING

1. Hook up when using a transformer

Min. 4 ohm

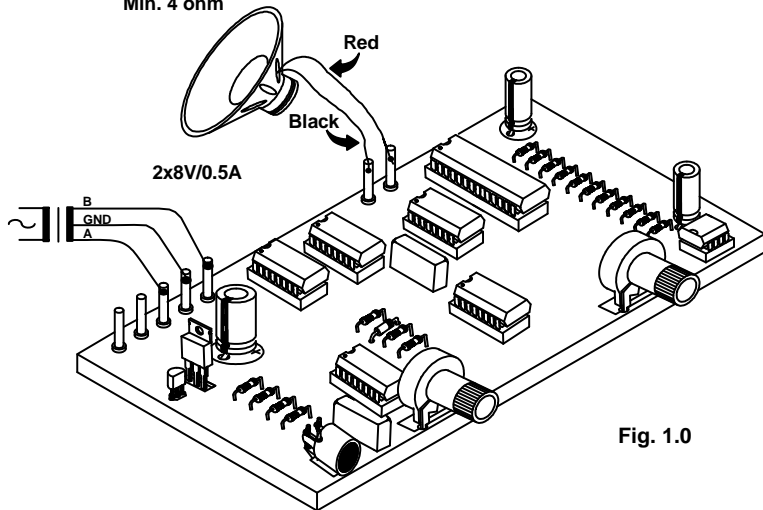

Fig. 1.0

2. Hook when using a battery :

Fig. 2.0

17. TEST & USE

- Turn all the trimmers to their centre position.
- Connect a loudspeaker of at least 4 ohm to the points LS.
- Connect the transformer (8V-0-8V) to the points VAC (**Fig. 1.0**). The center tap (0) should be connected to ground (GND, the middle one of the three VAC pins). The circuit can also be powered with direct current (9 to 12V, unregulated): in this case the negative goes to GND (the middle pin), the positive to one of the two outmost pins A or B (**Fig. 2.0**)

Make some noise, your loyal servant will promptly start barking.

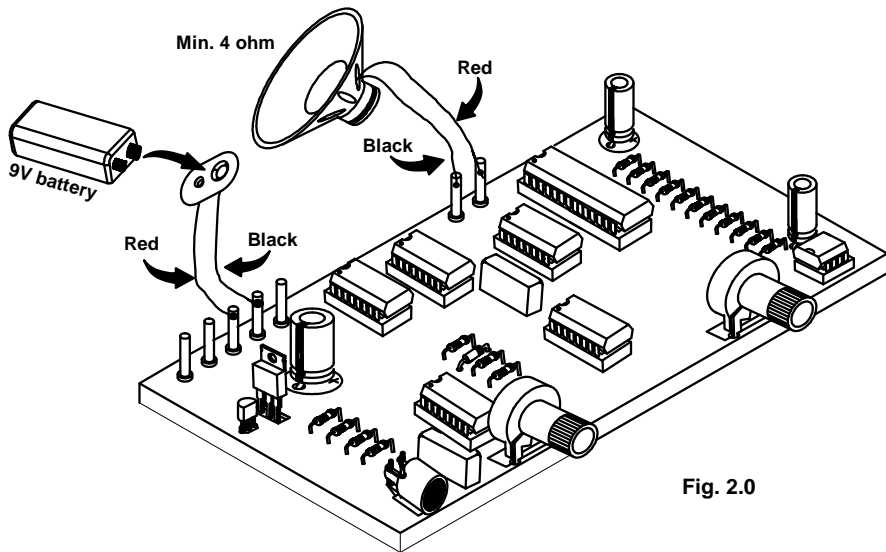
- With RV1 (TRIG LEVEL) you can adjust the sensitivity of the detector. In case the circuit is too sensitive you may replace R20 by a 1M (brown, black, green, gold) or 470K (yellow, violet, yellow, gold).
- RV4 is the volume potentiometer.
- With RV3 you can adjust the pitch of the barking. Remove J1 and install J2 to select the other dog.

After each triggering, the circuit continues barking for a while. With RV2 you can adjust that period. The circuit can also be triggered by other detectors if you like: to make the dog bark, you only have to short-circuit the TRIG points with a relay contact, push-button, etc...

Capacitor C3 takes care that the dog does not go on barking as long as the TRIG contacts are closed. To enable barking the whole time (e.g. with smoke detection), you may replace capacitor C3 by a wire link.

With a 4 ohm horn-type loudspeaker, the volume usually will appear sufficient. Should you still want a more powerful amplifier, you may connect it to AF OUT. Pay attention to the polarity! Fit a 100nF MKM capacitor for C16. If you are sure that the power amplifier already has a capacitor at the input, then you may fit a wire link for C16.

18. PCB layout.

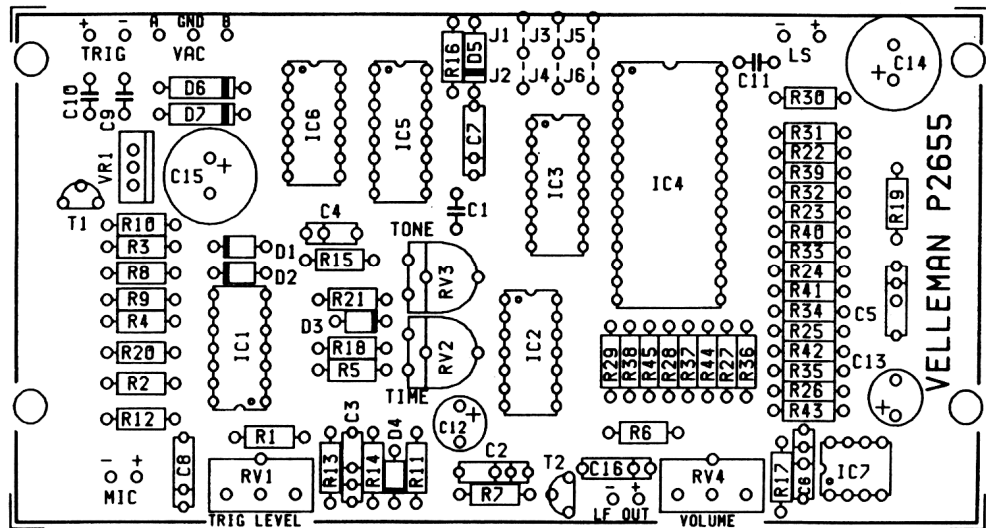

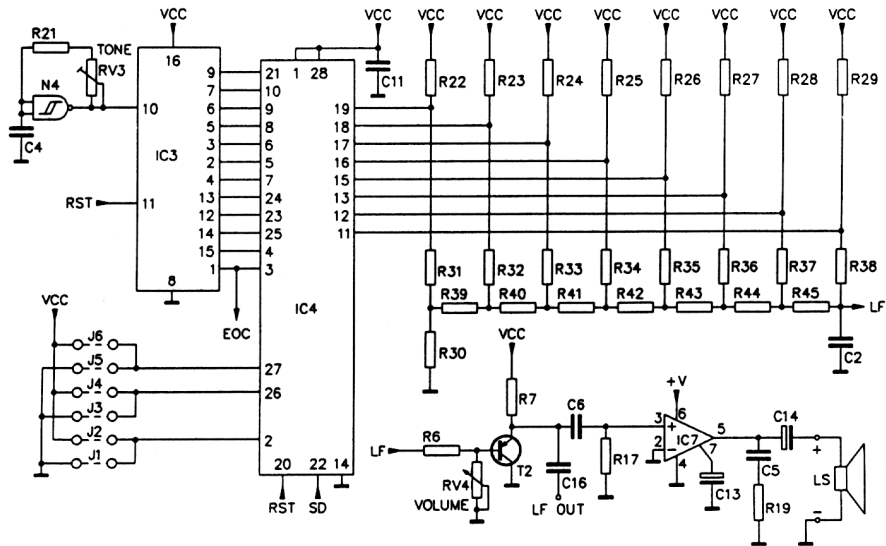

VELBUS
Velleman Home Automation System

ON--ALL--OFF
Sphere Alarm

VELBUS
Velleman Home Automation System

All appliances get intelligent, how about your home?
see our website : www.velbus.be

Modifications and typographical errors reserved
 © Velleman nv.
 H2655IP - 2012 - ED3

VELLEMAN NV
Legen Heirweg 33, 9890 Gavere
Belgium - Europe

