

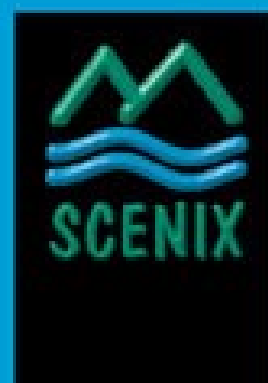

*User's
Manual*

SX Microcontrollers





Scenix™ SX Family User's Manual

Revision History

REVISION	RELEASE DATE	SUMMARY OF CHANGES
2.0	February 11, 1999	Updated to include SX48/52BD devices
2.01	June 14, 1999	Conyents the same as Rev 2.0 but removed the last chapter (Device Programming)
2.1	May 19, 1999	Updated to reflect the new revision of the SX18/20/28 AC devices (datecode Axyywwxx)
2.2	June 4, 1999	Deleted the recommended component values associated with resonator/crystal oscillator. This information is available in the datasheets.

©1999 Scenix Semiconductor, Inc. All rights reserved. No warranty is provided and no liability is assumed by Scenix Semiconductor with respect to the accuracy of this documentation or the merchantability or fitness of the product for a particular application. No license of any kind is conveyed by Scenix Semiconductor with respect to its intellectual property or that of others. All information in this document is subject to change without notice.

Scenix Semiconductor products are not authorized for use in life support systems or under conditions where failure of the product would endanger the life or safety of the user, except when prior written approval is obtained from Scenix Semiconductor.

Scenix™ and the Scenix logo are trademarks of Scenix Semiconductor, Inc.

I²C™ is a trademark of Philips Corporation

PIC® is a registered trademark of Microchip Technology, Inc.

Microchip® is a registered trademark of Microchip Technology, Inc.

SX-Key™ is a trademark of Parallax, Inc.

Microwire™ is a trademark of National Semiconductor Corporation

All other trademarks mentioned in this document are property of their respective companies.

Scenix Semiconductor, Inc., 3160 De La Cruz Boulevard, Suite 200, Santa Clara, CA 95054 USA
Telephone: +1 408 327 8888, Web site: <http://www.scenix.com>

Contents

Chapter 1	Overview	
1.1	Introduction	10
1.2	Key Features	10
1.3	CPU Features	11
1.4	I/O Features	11
1.5	Architecture	11
1.6	Programming and Debugging Support	12
1.7	Applications	12
1.8	Part Numbers and Pinout Diagrams	13
1.9	Pin Descriptions	17
Chapter 2	Architecture	
2.1	Introduction	19
2.2	Program Memory	20
2.3	Data Memory	20
2.3.1	Banks	20
2.3.2	SX18/20/28AC Bank Organization	21
2.3.3	SX48/52BD Bank Organization	23
2.3.4	Register Access Examples for SX48/52BD	24
2.4	Special-Function Registers	27
2.4.1	W (Working Register)	27
2.4.2	FSR (Indirect through FSR)	27
2.4.3	RTCC (Real-Time Clock/Counter)	29
2.4.4	PC (Program Counter)	29
2.4.5	STATUS (Status Register)	29
2.4.6	FSR (File Select Register)	31
2.4.7	RA through RE (Port Data Registers)	31
2.4.8	Port Control Registers and MODE Register	32
2.4.9	OPTION (Device Option Register)	34
2.5	Instruction Execution Pipeline	35
2.5.1	Clocking Modes	36
2.5.2	Pipeline Delays	36
2.5.3	Read-Modify-Write Considerations	37
2.6	Program Counter	37
2.6.1	Test and Skip	38
2.6.2	Jump Absolute	38
2.6.3	Jump Indirect and Jump Relative	39
2.6.4	Call	39
2.6.5	Return	40
2.7	Stack	41
2.8	Device Configuration Options	43

Chapter 3 Instruction Set

3.1	Introduction	50
3.2	Instruction Operands	50
3.3	Instruction Types	51
3.3.1	Logic Instructions	51
3.3.2	Arithmetic and Shift Instructions	51
3.3.3	Bitwise Operation Instructions	52
3.3.4	Data Movement Instructions	52
3.3.5	Program Control Instructions	52
3.3.6	System Control Instructions	52
3.4	Instruction Summary Tables	54
3.5	Equivalent Assembler Mnemonics	59
3.6	Detailed Instruction Descriptions	59
3.6.1	ADD fr,W Add W to fr	62
3.6.2	ADD W,fr Add fr to W	63
3.6.3	AND fr,W AND of fr and W into fr	64
3.6.4	AND W,fr AND of W and fr into W	65
3.6.5	AND W,#lit AND of W and Literal into W	66
3.6.6	BANK addr8 Load Bank Number into FSR(7:5)	67
3.6.7	CALL addr8 Call Subroutine	68
3.6.8	CLR fr Clear fr	70
3.6.9	CLR W Clear W	71
3.6.10	CLR !WDT Clear Watchdog Timer	72
3.6.11	CLRB fr.bit Clear Bit in fr	73
3.6.12	DEC fr Decrement fr	74
3.6.13	DECSZ fr Decrement fr and Skip if Zero	75
3.6.14	INC fr Increment fr	76
3.6.15	INCSZ fr Increment fr and Skip if Zero	77
3.6.16	IREAD Read Word from Instruction Memory	78
3.6.17	JMP addr9 Jump to Address	81
3.6.18	MOV fr,W Move W to fr	81
3.6.19	MOV M,#lit Move Literal to MODE Register	82
3.6.20	MOV M,W Move W to MODE Register	83
3.6.21	MOV !OPTION,W Move W to OPTION Register	84
3.6.22	MOV !rx,W Move Data Between W and Control Register ...	85
3.6.23	MOV W,fr Move fr to W	87
3.6.24	MOV W,/fr Move Complement of fr to W	88
3.6.25	MOV W,fr-W Move (fr-W) to W	89
3.6.26	MOV W,--fr Move (fr-1) to W	90
3.6.27	MOV W,++fr Move (fr+1) to W	91
3.6.28	MOV W,<<fr Rotate fr Left through Carry and Move to W ...	92
3.6.29	MOV W,>>fr Rotate fr Right through Carry and Move to W ..	93
3.6.30	MOV W,<>fr Swap High/Low Nibbles of fr and Move to W ..	94
3.6.31	MOV W,#lit Move Literal to W	95
3.6.32	MOV W,M Move MODE Register to W	96
3.6.33	MOVSZ W, --fr Move (fr-1) to W and Skip if Zero	97
3.6.34	MOVSZ W, ++fr Move (fr+1) to W and Skip if Zero	98

3.6.35	NOP	No Operation	99
3.6.36	NOT fr	Complement of fr into fr	100
3.6.37	OR fr,W	OR of fr and W into fr	101
3.6.38	OR W,fr	OR of W and fr into W	102
3.6.39	OR W,#lit	OR of W and Literal into W	103
3.6.40	PAGE addr12	Load Page Number into STATUS(7:5)	104
3.6.41	RET	Return from Subroutine	105
3.6.42	RETI	Return from Interrupt	106
3.6.43	RETIW	Return from Interrupt and Adjust RTCC with W	106
3.6.44	RETP	Return from Subroutine Across Page Boundary	108
3.6.45	RETW lit	Return from Subroutine with Literal in W	109
3.6.46	RL fr	Rotate fr Left through Carry	110
3.6.47	RR fr	Rotate fr Right through Carry	111
3.6.48	SB fr.bit	Test Bit in fr and Skip if Set	112
3.6.49	SETB fr.bit	Set Bit in fr	113
3.6.50	SLEEP	Power Down Mode	114
3.6.51	SNB fr.bit	Test Bit in fr and Skip if Clear	115
3.6.52	SUB fr,W	Subtract W from fr	116
3.6.53	SWAP	Swap High/Low Nibbles of fr	118
3.6.54	TEST fr	Test fr for Zero	119
3.6.55	XOR fr,W	XOR of fr and W into fr	120
3.6.56	XOR W,fr	XOR of W and fr into W	121
3.6.57	XOR W,#lit	XOR of W and Literal into W	122

Chapter 4 Clocking, Power Down, and Reset

4.1	Introduction	123
4.2	Clocking Options	123
4.2.1	Clock/Instruction Rate Option (Compatible or Turbo Mode)	123
4.2.2	Internal RC Oscillator	124
4.2.3	External RC Oscillator	124
4.2.4	External Crystal/Resonator (XT, LP, or HS Mode)	125
4.2.5	External Clock Signal	126
4.3	Power Down Mode	126
4.3.1	Entering the Power Down Mode	127
4.3.2	Waking Up from the Power Down Mode	127
4.4	Multi-Input Wakeup/Interrupt	128
4.4.1	Port B Configuration for Multi-Input Wakeup/Interrupt	128
4.4.2	Reading and Writing the Wakeup Pending Bits	130
4.5	Reset	131
4.5.1	Register States Upon Different Resets	131
4.5.2	Power-On Reset	133
4.5.3	Wakeup from the Power Down Mode	134
4.5.4	Brown-Out Reset	136
4.5.5	Watchdog Timeout	136
4.5.6	$\overline{\text{MCLR}}$ Input Signal (Master Clear Reset)	136

Chapter 5	Input/Output Ports	
5.1	Introduction	137
5.2	Reading and Writing the Ports	137
5.3	Port Configuration	138
5.3.1	Accessing the Port Control Registers	139
5.3.2	MODE Register	139
5.3.3	Port Configuration Example	141
5.3.4	Port Configuration Registers	142
5.3.5	Port Configuration Upon Reset	143
5.3.6	Port Block Diagram	143
Chapter 6	Timers and Interrupts	
6.1	Introduction	145
6.2	Real-Time Clock/Counter	145
6.2.1	Prescaler Register	146
6.2.2	Maximum Count	146
6.2.3	RTCC Operation as a Real-Time Clock or Timer	147
6.2.4	RTCC Operation as an Event Counter	147
6.2.5	RTCC Overflow Interrupts	147
6.3	Watchdog Timer	148
6.3.1	Watchdog Timeout Period	148
6.3.2	Watchdog Operation in the Power Down Mode	149
6.4	Interrupts	149
6.4.1	Single-Level Interrupt Operation	150
6.4.2	Interrupt Sequence	150
6.4.3	RTCC Interrupts	151
6.4.4	Port B Interrupts	151
6.4.5	Device-Specific Interrupts	152
6.4.6	Return-from-Interrupt Instructions	153
6.4.7	Interrupt Example	153
Chapter 7	Analog Comparator	
7.1	Introduction	154
7.2	Comparator Enable/Status Register (CMP_B)	154
7.2.1	Accessing the CMP_B Register	155
7.3	Comparator Operation	155
Chapter 8	Multi-Function Timers	
8.1	Introduction	160
8.2	Timer Operating Modes	161
8.2.1	PWM Mode	161
8.2.2	Software Timer Mode	161
8.2.3	External Event Mode	162
8.2.4	Capture/Compare Mode	162

8.3	Timer Pin Assignments	163
8.4	Timer Control Registers	163
8.4.1	Timer T1 Control A Register (T1CNTA)	164
8.4.2	Timer T1 Control B Register (T1CNTB)	164
8.4.3	Timer T2 Control A Register (T2CNTA)	165
8.4.4	Timer T2 Control B Register (T2CNTB)	166

List of Figures

Figure 1-1	SX18/20/28 Pin Assignments	13
Figure 1-2	SX48/52BD Pin Assignments.	14
Figure 1-3	Part Numbering Reference Guide.	16
Figure 2-1	SX28AC Block Diagram	19
Figure 2-2	SX48/52BD Register Access Modes	25
Figure 2-3	Program Counter Loading for Jump Instruction.	40
Figure 2-4	Program Counter Loading for Call Instruction.	40
Figure 2-5	Stack Operation for a “Call” Instruction.	42
Figure 2-6	Stack Operation for a “Return” Instruction	42
Figure 2-7	Device Configuration Register Formats	44
Figure 3-1	Program Counter Loading for Call Instruction.	78
Figure 3-2	Rotate fr Left Through Carry into W	92
Figure 3-3	Rotate fr Right Through Carry into W	93
Figure 3-4	Rotate fr Left Through Carry	110
Figure 3-5	Rotate fr Right Through Carry	111
Figure 4-1	External RC Oscillator Connections.	125
Figure 4-2	Crystal or Ceramic Resonator Connections	126
Figure 4-3	External Clock Signal Connection	127
Figure 4-4	Multi-Input Wakeup/Interrupt Block Diagram.	128
Figure 4-5	On-Chip Reset Circuit Block Diagram.	131
Figure 4-6	Power-On Reset Timing, Fast VDD Rise Time	133
Figure 4-7	Power-On Reset Timing, VDD Rise Time Too Slow	134
Figure 4-8	External Power-On $\overline{\text{MCLR}}$ Signal	134
Figure 4-9	Power-On Reset Timing, Separate $\overline{\text{MCLR}}$ Signal	134
Figure 5-1	Port B Pin Block Diagram	144
Figure 6-1	RTCC Block Diagram	146
Figure 6-2	Interrupt Logic Block Diagram.	152
Figure 7-1	Comparator Block Diagram	156
Figure 8-1	Multi-Function Timer Block Diagram.	160

List of Tables

Table 1-1	Device Package Names	15
Table 1-2	Pin Descriptions	18
Table 2-1	RAM Register Map	22
Table 2-2	Register Summary	28
Table 2-3	STATUS Register Bits	30
Table 2-4	MODE Register Settings for SX18/20/28AC	32
Table 2-5	MODE Register Settings for SX48/52BD	33
Table 2-6	Prescaler Divide-By Factors	35
Table 2-7	Pipeline Execution Sequence	36
Table 2-8	Return-from-Subroutine/Interrupt Instructions	41
Table 2-9	FUSE Word Register Configuration Bits for Sx18/20/28AC.....	45
Table 2-10	FUSEX Word Register Configuration Bits for SX18/20/28AC	46
Table 2-11	FUSEX Word Register Configuration Bits for SX48/52BD	47
Table 2-12	FUSEX Word Register Configuration Bits for Sx48/52BD.....	49
Table 3-1	Logic Instructions	55
Table 3-2	Arithmetic and Shift Instructions (Sheet 1 of 2)	55
Table 3-3	Bitwise Operation Instructions	56
Table 3-4	Data Movement Instructions (Sheet 1 of 2)	56
Table 3-5	Program Control Instructions	58
Table 3-6	System Control Instructions	58
Table 3-7	Equivalent Assembler Mnemonics	59
Table 3-8	Key to Abbreviations and Symbols	61
Table 4-1	Register States Upon Different Resets	132
Table 5-1	MODE Register Settings for SX18/20/28AC	140
Table 5-2	MODE Register Settings for SX48/52BD	140
Table 6-1	Watchdog Timeout Settings	149
Table 8-1	Timer T1/T2 Pin Assignments	163
Table 8-2	T1CNTA Register Bits	164
Table 8-3	T1CNTB Register Bits	164
Table 8-4	T2CNTA Register Bits	165
Table 8-5	T2CNTB Register Bits	166



Chapter 1

Overview

1.1 Introduction

The Scenix SX family of high-performance 8-bit microcontrollers provide an economical solution to a wide range of embedded controller applications. These devices are fabricated with an advanced CMOS process technology. This advanced process, combined with a RISC-based architecture, allows high-speed computation, flexible I/O control, and efficient data manipulation. Throughput is enhanced by operating the device at frequencies up to 50 MHz and by using an optimized instruction set that includes mostly single-cycle instructions.

On-chip core functions include a general-purpose 8-bit timer with prescaler, an analog comparator, a brown-out detector, a watchdog timer, a power-save mode with multi-source wakeup capability, an internal R/C oscillator, user-selectable clock modes, and high-current outputs. Additional features are provided by individual members of the SX family according to the system requirements, such as PWM timers and additional I/O ports.

1.2 Key Features

These are the key core features of SX family devices:

- 50 MIPS performance at 50 MHz oscillator frequency
- From 2,048 to 4,096 words of EE/Flash program memory, 12 bits wide, rated for 10,000 rewrite cycles
- From 136 to 256 bytes of general-purpose SRAM memory
- In-system programming capability through OSC pins
- User-selectable clock modes using an internal oscillator, external clock signal, or external oscillator (crystal or RC)
- Analog comparator
- Brown-out detector
- Multi-Input Wakeup (MIWU) on eight pins
- Fast lookup capability through run-time readable code
- Complete development tool support available from third-party vendors

1.3 CPU Features

These are the key features of the device CPU:

- Fully static design – DC to 50 MHz operation
- 20 ns instruction cycle time at 50 MHz
- Mostly single-cycle instructions
- 8-level deep hardware subroutine stack
- Single-level interrupt processing
- Fixed interrupt response time: 60 ns internal, 100 ns external at 50 MHz (Turbo Mode)
- Hardware context save/restore for interrupt processing

1.4 I/O Features

These are the key features of the device I/O ports:

- Software-selectable I/O configuration
- Each pin programmable as an input or output
- TTL or CMOS level selection on inputs
- Internal weak pull-up selection on inputs ($\sim 20\text{ k}\Omega$ to V_{DD})
- Schmitt trigger inputs (except Port A)
- Symmetrical drive on Port A outputs (same V_{drop} +/-)
- All outputs capable of sinking/sourcing 30 mA

1.5 Architecture

The SX family uses a modified Harvard architecture. This architecture is based on having two separate memories with separate address buses, one for the program and one for data, while allowing transfer of data from program memory to SRAM. This ability allows accessing data tables from program memory. The advantage of this architecture is that instruction fetch and memory transfers can be overlapped in a multi-stage pipeline, which means the next instruction can be fetched from program memory while the current instruction is being executed.

The SX family implements a four-stage pipeline (fetch, decode, execute, and write back), which results in a throughput of one instruction per clock cycle. At the maximum operating frequency of 50 MHz, instructions are executed at the rate of one per 20-ns clock cycle.

1.6 Programming and Debugging Support

SX devices are supported by complete development tool packages offered by third-party vendors. Each development tool package provides an integrated development environment including editor, macro assembler, debugger, and device programmer. For more information on the available development tool packages, contact Scenix Semiconductor.

1.7 Applications

Emerging applications and advances in existing ones require higher performance while maintaining low cost and fast time-to-market.

SX devices provide solutions for many familiar applications such as process controllers, electronic appliances/tools, security/monitoring systems, and telecommunication devices such as FSK modems with DTMF detection/generation and Caller ID functions. In addition, the enhanced throughput of the device allows efficient development of software modules called “Virtual PeripheralTM modules” to replace on-chip hardware peripherals. The concept of Virtual PeripheralTM provides benefits such as simple implementation, reduced component count, fast time to market, increased flexibility in design, and overall system cost reduction.

Here are some examples of Virtual PeripheralTM applications:

- Serial interfaces such as I2CTM, MicrowireTM, SPI, IR transceivers
- Frequency generation and measurement
- Spectrum analysis
- Multi-tasking, interrupts, and networking
- Resonance loops
- DRAM drivers
- Music and voice synthesis
- PPM/PWM output
- Delta/Sigma ADC
- DTMF generation/detection
- FSK generation/detection
- Quadrature encoder/decoder
- Proportional Integral Derivative (PID) and servo control
- Video controller

1.8 Part Numbers and Pinout Diagrams

This user's guide describes the following Scenix SX microcontrollers:

- SX18AC, SX20AC, and SX28AC microcontrollers (with 2K program memories)
- SX48BD and SX52BD microcontrollers (with 4K program memories and multi-function timers)

The SX18/20/28AC devices are available in the pin configurations shown in [Figure 1-1](#). These devices are functionally the same except that the 18-pin and 20-pin devices do not have the port pins RC0 through RC7. Therefore, Port C cannot be used in the smaller packages.

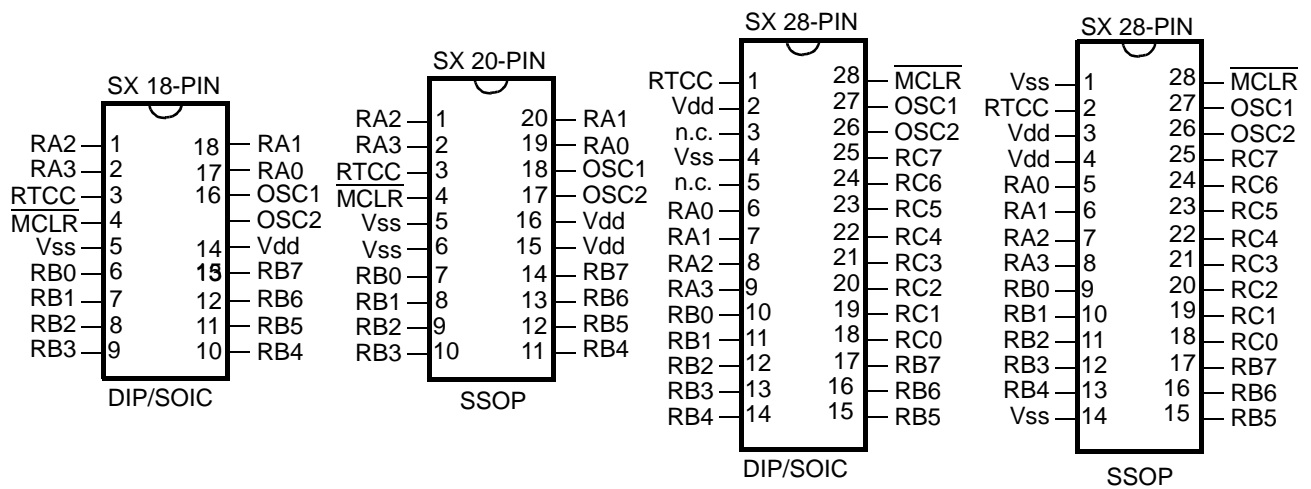

Figure 1-1 SX18/20/28 Pin Assignments

The SX48/52BD devices are available in the pin configurations shown in Figure 1-2. These devices are functionally the same except that the 48-pin device does not have the port pins RA4 through RA7. Therefore, the upper four pins of Port A are not available in the smaller package.

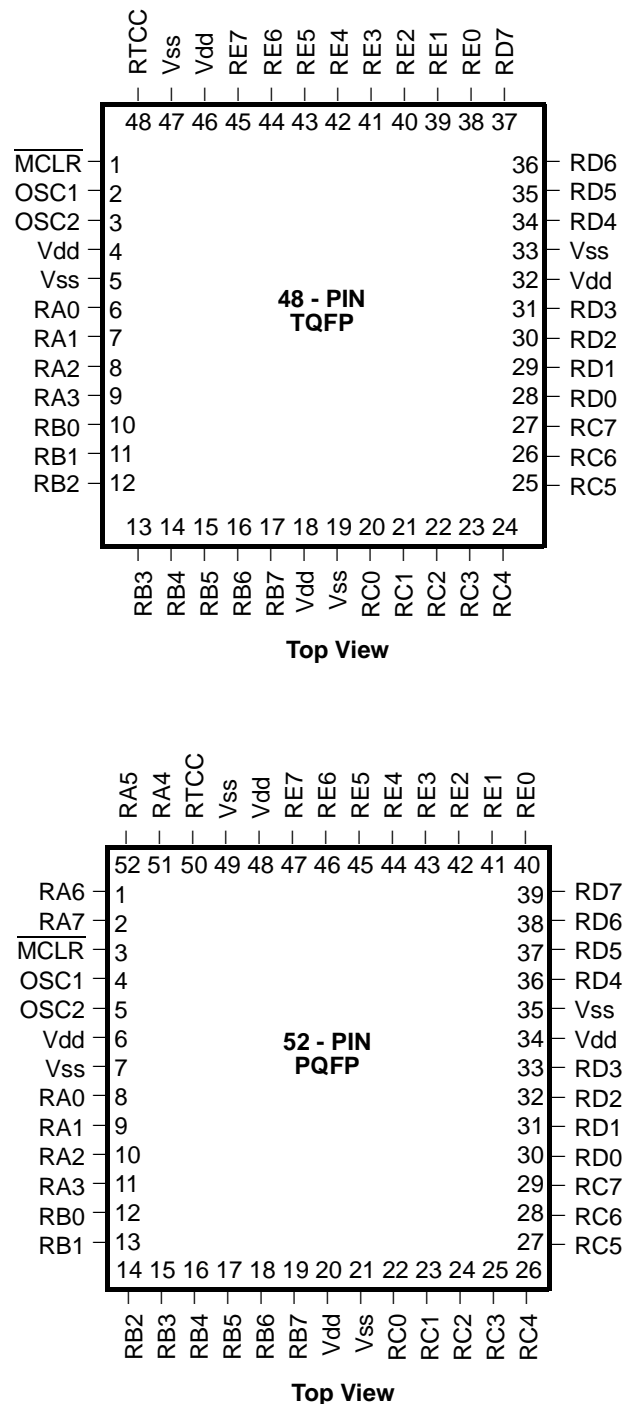

Figure 1-2 SX48/52BD Pin Assignments

Table 1-1 is a list of the available SX device packages and the corresponding number of pins, number of I/O pins, program (flash) memory size, and general-purpose RAM size. Use this table as a guide for ordering the parts that fit your requirements.

Table 1-1 Device Package Names

Device	Pins	I/O	EE/Flash (Words)	RAM (Bytes)
SX18AC/SO	18	12	2K	136
SX18AC/DP	18	12	2K	136
SX20AC/SS	20	12	2K	136
SX28AC/SO	28	20	2K	136
SX28AC/DP	28	20	2K	136
SX28AC/SS	28	20	2K	136
SX48BD/TQFP	48	36	4K	256 + 15 global regs.
SX52BD/PQFP	52	40	4K	256 + 15 global regs.

Figure 1-3 is a diagram showing the general naming conventions for SX family devices. The part number consists of several fields that specify the manufacturer, pin count, feature set, memory size, supply voltage, operating temperature range, and package type, as indicated in Figure 1-3.

Throughout this manual, the term “SX” refers to all the devices listed in Table 1-1, except where indicated otherwise.

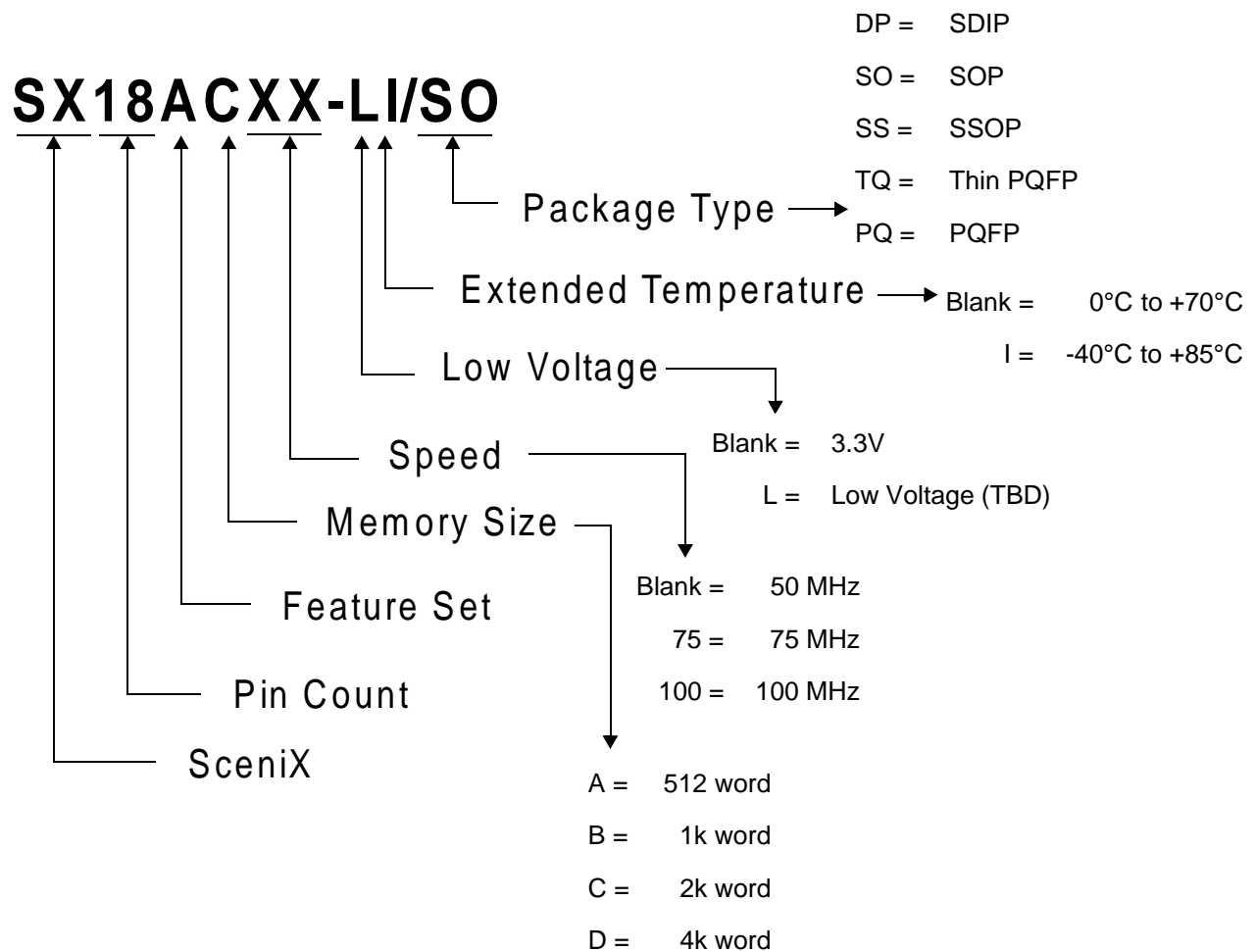

Figure 1-3 Part Numbering Reference Guide

1.9 Pin Descriptions

Table 1-2 describes the SX device pins. For each pin, the table shows the pin type (input, output, or power), the input voltage levels (TTL, CMOS, or Schmitt trigger), and the pin function. Note that not all of these pins are available on all the devices. For example, some devices have fewer I/O pins. Also note that only the core functions of the pins are shown in the table. Some pins have additional functions in certain SX devices.

The following abbreviations are used in the table:

- I = device input
- O = device output
- I/O = bidirectional I/O pin
- P = power supply pin
- NA = not applicable
- TTL = TTL input levels
- CMOS = CMOS input levels
- ST = Schmitt trigger input
- MIWU = Multi-Input Wakeup

Table 1-2 Pin Descriptions

Name	Pin Type	Input Levels	Description
RA0-RA7	I/O	TTL/CMOS	Port A bidirectional I/O pin; symmetrical source / sink capability
RB0	I/O	TTL/CMOS/ST	Port B bidirectional I/O pin; MIWU input; comparator output
RB1	I/O	TTL/CMOS/ST	Port B bidirectional I/O Pin; MIWU input; comparator negative input
RB2	I/O	TTL/CMOS/ST	Port B bidirectional I/O pin; MIWU input; comparator positive input
RB3-RB7	I/O	TTL/CMOS/ST	Port B bidirectional I/O pins; MIWU inputs
RC0-RC7	I/O	TTL/CMOS/ST	Port C bidirectional I/O pins
RD0-RD7	I/O	TTL/CMOS/ST	Port D bidirectional I/O pins
RE0-RE7	I/O	TTL/CMOS/ST	Port E bidirectional I/O pins
RTCC	I	ST	Input to Real Time Clock/Counter
$\overline{\text{MCLR}}$	I	ST	Master Clear reset input – active low
OSC1/In/Vpp	I	ST	Crystal oscillator input - external clock source input
OSC2/Out	O	CMOS	Crystal oscillator output – in R/C mode, internally pulled to Vdd through weak pullup
Vdd	P	NA	Positive supply pins
Vss	P	NA	Ground pins



Chapter 2

Architecture

2.1 Introduction

The SX device is a complete 8-bit RISC microcontroller with an electrically erasable (flash) program memory and in-system programming capability. The device can operate with a clock rate of up to 50 MHz and can execute instructions at a rate of up to 50 million instructions per second.

The SX device has multi-pin I/O ports, an internal oscillator, a Watchdog timer, a Real-Time Clock/Counter, an analog comparator, power-on and brownout reset control, and Multi-Input Wakeup capability. Figure 2-1 is a block diagram showing the core features of the basic device. Additional features are available with some SX family members. For example, some devices offer more RAM, a larger EEPROM program memory, or additional peripheral modules such as multi-function timers.

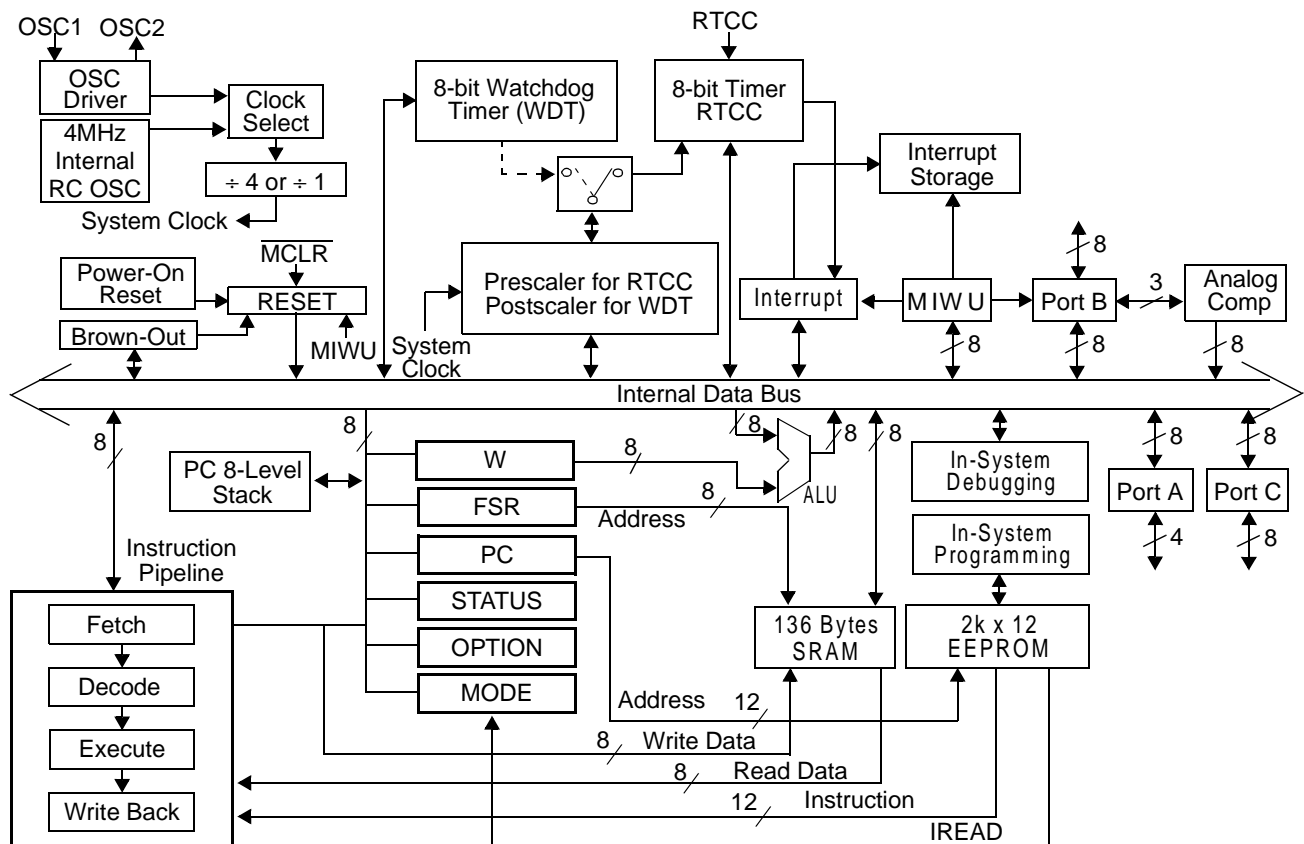

Figure 2-1 SX28AC Block Diagram

The SX device uses a modified Harvard architecture, in which the program and data are stored in separate memory spaces. The advantage of this architecture is that instruction fetches and data transfers can be overlapped with a multi-stage pipeline, which means the next instruction can be fetched from program memory while the current instruction is being executed uses data from the data memory. This device has a “modified” Harvard architecture because instructions are available for transferring data from the program memory to the data memory.

2.2 Program Memory

The program memory holds the application program for the device. It is an electrically erasable, flash-programmed memory containing 2,048 words for the SX18/20/28AC or 4,096 words for the SX48/52BD, with 12 bits per word. Each memory location holds a single 12-bit instruction opcode or 12 bits of fixed data that can be accessed by the program. The memory can be programmed and reprogrammed through the device oscillator pins, even with the device installed in the target system.

The program memory is addressed by the program counter, a register of 11 bits for the SX18/20/28AC or 12 bits for the SX48/52BD. Operation of the program counter is described in detail in [Section 2.6](#).

2.3 Data Memory

The data memory is a RAM-based register set consisting of general-purpose registers and dedicated-purpose registers. The number of registers depends on the SX device type. The SX18/20/28AC has 136 general-purpose registers and eight dedicated-purpose registers. The SX48/52BD has 262 general-purpose registers and ten dedicated-purpose registers. All of these registers are eight bits wide. The registers are organized into banks, allowing the SX instructions to address the registers using just five bits of the 12-bit instruction opcode.

Because the registers are organized into banks or “files,” these memory-mapped registers are called “file registers.” In the descriptions of the SX instructions in [Chapter 3](#), the abbreviation “fr” represents a 5-bit register selection value encoded into the instruction opcode.

2.3.1 Banks

The SX device can be programmed to use any one of the data memory banks at any given time. The high-order bits in the File Select Register (FSR) specify the current bank number. To change from one bank to another, the program can either write an eight-bit value to the FSR register or use the “bank” instruction. The “bank” instruction writes the three high-order bits in the FSR register without affecting the other bits in the register.

The organization of the data memory banks is somewhat different for the various SX family members:

- SX18A/SX20A/SX28A: eight banks of 32 bytes per bank, with global registers mapped to the bottom 16 bytes in all banks
- SX48BD/SX52BD: 16 banks of eight bytes per bank, with global registers mapped into a separate bank

The following sections describe the bank organization in detail.

2.3.2 SX18/20/28AC Bank Organization

The data memory of the SX18AC, SX20AC, or SX28AC is a RAM-based register set consisting of 136 general-purpose registers and eight dedicated-purpose registers. All of these registers are eight bits wide. The registers are organized into eight banks, designated Bank 0 through Bank 7.

Each SX instruction that accesses a data memory register contains a 5-bit field in the instruction opcode that specifies the register to be accessed. The abbreviation “fr” represents the 5-bit register address designator. For example, the instruction description “mov fr,W” means that a 5-bit value or label must be substituted for “fr” in the instruction, such as “mov \$0F,W” (to move the contents of the working register W into file register 0Fh).

The SX device can be programmed to use any one of the eight banks at any given time. The three high-order bits in the File Select Register (FSR) specify the current bank number. To change from one bank to another, the program can either write an eight-bit value to the FSR register or use the “bank” instruction. The “bank” instruction writes the three bank-selection bits in the FSR register without affecting the other bits in the register. Bank 0 is selected by default upon power-up or reset.

Within each bank, there are 32 available addresses, ranging from 00h to 1Fh. [Table 2-1](#) shows the organization of file registers in the memory-mapped address space. The numbers along the left side the table (ranging from \$00 to \$1F) show the 32 possible register addresses that can be specified in the instruction. The bank numbers listed across the top (ranging from 0 to 7) are the numbers that can be programmed into the three high-order bits of the FSR register. The entries inside the table show the registers accessed by each combination of register address and bank selection.

The 5-bit register addresses along the left side are shown as they are written in the syntax of the SX assembly language, using a dollar sign (\$) indicating the beginning of a hexadecimal value. Inside the table, the register addresses are shown as 8-bit hexadecimal values.

Table 2-1 RAM Register Map

	Bank 0	Bank 1	Bank 2	Bank 3	Bank 4	Bank 5	Bank 6	Bank 7
\$00	INDF	INDF	INDF	INDF	INDF	INDF	INDF	INDF
\$01	RTCC	RTCC	RTCC	RTCC	RTCC	RTCC	RTCC	RTCC
\$02	PC	PC	PC	PC	PC	PC	PC	PC
\$03	Status	Status	Status	Status	Status	Status	Status	Status
\$04	FSR	FSR	FSR	FSR	FSR	FSR	FSR	FSR
\$05	RA	RA	RA	RA	RA	RA	RA	RA
\$06	RB	RB	RB	RB	RB	RB	RB	RB
\$07	RC	RC	RC	RC	RC	RC	RC	RC
\$08	08h	08h	08h	08h	08h	08h	08h	08h
\$09	09h	09h	09h	09h	09h	09h	09h	09h
\$0A	0Ah	0Ah	0Ah	0Ah	0Ah	0Ah	0Ah	0Ah
\$0B	0Bh	0Bh	0Bh	0Bh	0Bh	0Bh	0Bh	0Bh
\$0C	0Ch	0Ch	0Ch	0Ch	0Ch	0Ch	0Ch	0Ch
\$0D	0Dh	0Dh	0Dh	0Dh	0Dh	0Dh	0Dh	0Dh
\$0E	0Eh	0Eh	0Eh	0Eh	0Eh	0Eh	0Eh	0Eh
\$0F	0Fh	0Fh	0Fh	0Fh	0Fh	0Fh	0Fh	0Fh
\$10	10h	30h	50h	70h	90h	B0h	D0h	F0h
\$11	11h	31h	51h	71h	91h	B1h	D1h	F1h
\$12	12h	32h	52h	72h	92h	B2h	D2h	F2h
\$13	13h	33h	53h	73h	93h	B3h	D3h	F3h
\$14	14h	34h	54h	74h	94h	B4h	D4h	F4h
\$15	15h	35h	55h	75h	95h	B5h	D5h	F5h
\$16	16h	36h	56h	76h	96h	B6h	D6h	F6h
\$17	17h	37h	57h	77h	97h	B7h	D7h	F7h
\$18	18h	38h	58h	78h	98h	B8h	D8h	F8h
\$19	19h	39h	59h	79h	99h	B9h	D9h	F9h
\$1A	1Ah	3Ah	5Ah	7Ah	9Ah	BAh	DAh	FAh
\$1B	1Bh	3Bh	5Bh	7Bh	9Bh	BBh	DBh	FBh
\$1C	1Ch	3Ch	5Ch	7Ch	9Ch	BCh	DCh	FCh
\$1D	1Dh	3Dh	5Dh	7Dh	9Dh	BDh	DDh	FDh
\$1E	1Eh	3Eh	5Eh	7Eh	9Eh	BEh	DEh	FEh
\$1F	1Fh	3Fh	5Fh	7Fh	9Fh	BFh	DFh	FFh

For the first 16 addresses that can be specified in an instruction (00h through 0Fh), the same 16 registers are accessed, irrespective of the bank setting. Therefore, these 16 “global” registers are always accessible. The first eight are dedicated-purpose registers (INDF, RTCC, PC, and so on), and the next eight are general-purpose registers. In [Table 2-1](#), these registers are shown shaded in Bank 1 through Bank 7 to indicate that they are the same registers as in Bank 0.

For the upper 16 addresses that can be specified in an instruction (10h through 1Fh), a different set of registers is accessed in each bank. This allows as many as 128 different registers to be accessed in this memory range, although only 16 are accessible at any given time.

The total number of general-purpose registers is 24 in Bank 0 (from 08h to 1Fh) and 16 in each of the remaining seven banks (from 10h to 1Fh in each bank), for a total of 136 registers. In the SX18AC and SX20AC, an additional general-purpose register is available at address 08h because there is no Port C register occupying that address.

There are two addressing modes for the SX18/20/28AC, called the indirect and direct modes. The addressing mode used for register access depends on the 5-bit “fr” value used in the instruction:

- indirect mode: fr = 00h
- direct mode: fr = 01h through 1Fh

For indirect addressing (fr=00), the File Select Register (FSR) specifies the register to be accessed. FSR is an 8-bit, memory-mapped register (at address 04h) which serves as an 8-bit pointer into data memory for indirect addressing.

For direct addressing with bit 4 of “fr” equal to 0 (fr=01-0F), Bank 0 is accessed and the value of “fr” itself specifies the register to be accessed. In this case, a “global” register in Bank 0 is accessed (01h through 0Fh) and the FSR register is ignored.

For direct addressing with bit 4 of “fr” equal to 1 (fr=10-1F), the three high-order bits of the FSR register specify the bank number accessed, and the five bits of “fr” specify which register in that bank is accessed. In this case, the upper half of a bank is accessed.

2.3.3 SX48/52BD Bank Organization

The data memory of the SX48BD or SX52BD is a RAM-based register set consisting of 262 general-purpose registers and nine special-purpose registers. It is organized into 16 banks, designated Bank 0 through Bank F, each containing 16 registers, plus an additional bank of 16 global registers.

Each SX instruction that accesses a data memory register contains a 5-bit field in the instruction opcode that specifies the register to be accessed. The abbreviation “fr” represents the 5-bit register address designator. For example, the instruction description “mov fr,W” means that a 5-bit value or label must be substituted for “fr” in the instruction, such as “mov \$0F,W” (to move the contents of the working register W into file register 0Fh).

There are three different addressing modes for the SX48/52BC, called the indirect, direct, and semi-direct modes. The addressing mode used for register access depends on the 5-bit “fr” value used in the instruction:

- indirect mode: fr = 00h
- direct mode: fr = 01h through 0Fh
- semi-direct mode: fr = 10h through 1Fh

For indirect addressing (fr=00), the File Select Register (FSR) specifies the register to be accessed. FSR is an 8-bit, memory-mapped register (at address 04h) which serves as an 8-bit pointer into data memory for indirect addressing. In this mode, the global register bank and Bank 1 through Bank F are accessible. Bank 0 is not accessible.

For direct addressing (fr=01-0F), the value of “fr” itself specifies the register to be accessed, and the FSR register is ignored. For this addressing mode, only the global register bank is accessible. To gain access to any other bank, you must use either indirect or semi-direct addressing.

For semi-direct addressing (fr=10-1F), the bank number is selected by the four high-order bits of FSR, and the register within that bank is selected by the four low-order bits of “fr.” In other words, the register address is obtained by combining the four high-order bits of FSR with the four low-order bits of “fr”. In this addressing mode, the low-order bits of FSR are ignored. Bank 0 through Bank F are accessible, but the global register bank is not accessible.

Figure 2-2 is a diagram showing how register addressing works in the indirect, direct, and semi-direct modes for SX48/52BD devices.

The 16 global registers are always accessible by direct addressing, regardless of what is contained in the FSR register. The global registers are also accessible with indirect addressing, but they are not accessible with semi-direct addressing. Of the 16 global registers, nine are special-purpose registers (INDF, RTCC, PC, STATUS, and so on), and six are general-purpose registers. All of the registers in Bank 0 through Bank F are general-purpose registers.

To change the contents of the FSR register, the program can either write an eight-bit value to the FSR register or use the “bank” instruction. The “bank” instruction writes the three high-order bits in the FSR register and clears bit 4 without affecting the other bits in the register. Thus, the “bank” instruction lets you quickly change from one even-numbered bank to another. To select an odd-numbered bank, you must set bit 4 of the FSR register after you use the “bank” instruction.

2.3.4 Register Access Examples for SX48/52BD

Here is an example of an instruction that uses direct addressing:

```
inc $0F    ;increment file register 0Fh
```

This instruction increments the contents of file register 0Fh in the global register bank. It does not matter what is contained in the FSR register.

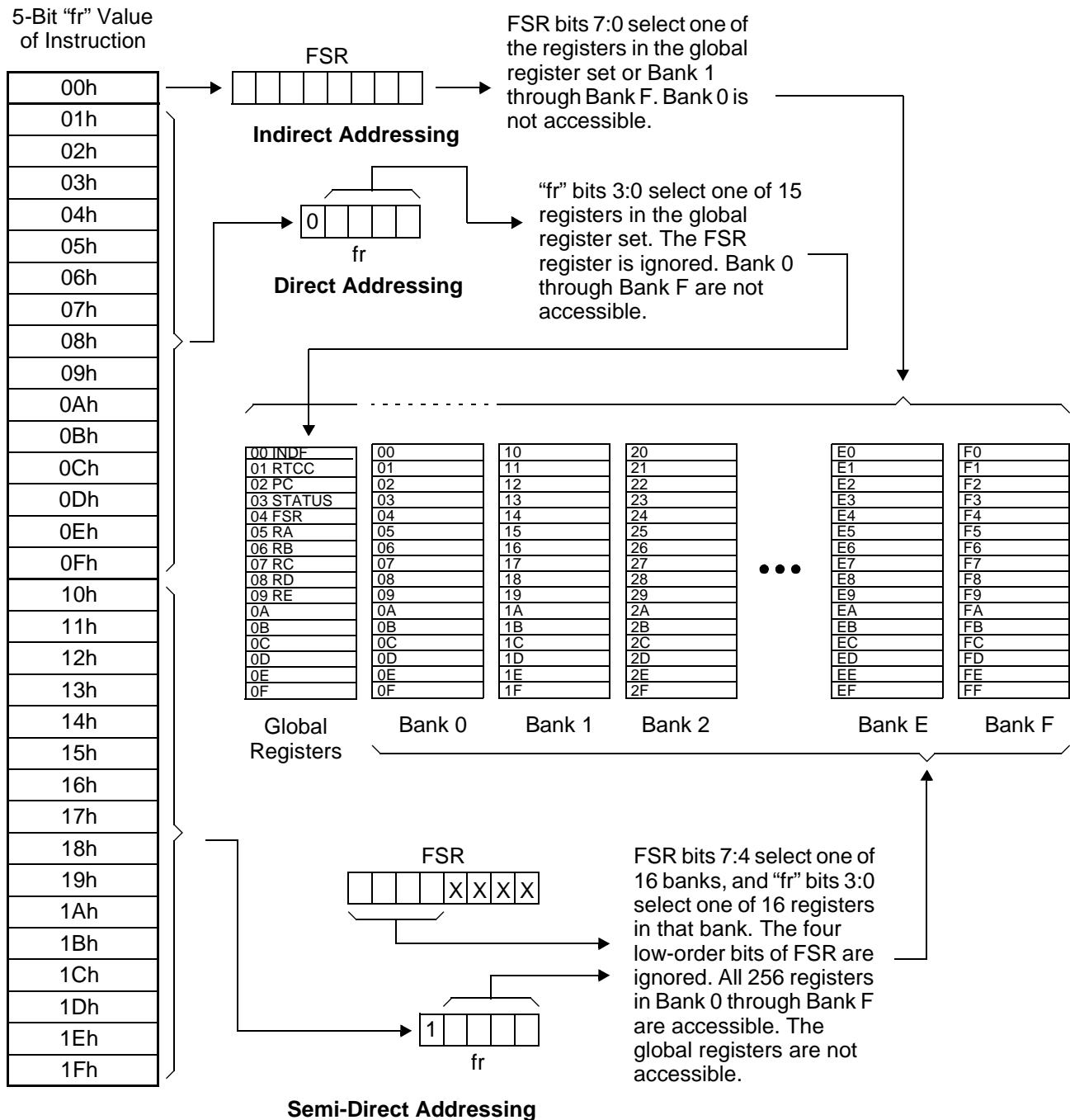

Figure 2-2 SX48/52BD Register Access Modes

To gain access to any register outside of the global register bank, it is necessary to use semi-direct or indirect addressing. In that case, you need to make sure that the FSR register contains the correct value for accessing the desired bank.

Here is an example that uses semi-direct addressing:

```

mov  W,#$F0 ;load W with F0h
mov  FSR,W  ;set upper 4 bits of FSR (Bank F)
inc  $1F    ;increment file register FFh

```

In this example, “FSR” is a label that represents the value 04h, which is the address of the FSR register in the global register bank. Note that the FSR register is itself a memory-mapped global register at address 04h, which is always accessible using direct addressing.

To use the “bank” instruction, in the syntax of the assembly language, you specify the desired bank number as an 8-bit address. The assembler encodes the three high-order bits of the specified value into the instruction opcode and ignores the low-order bits, and always clears bit 4 of the FSR register (in other words, selects an even-numbered bank). For example, to increment file register 2Fh, you could use the following instructions:

```

bank $20    ;select Bank 2 in FSR
inc  $1F    ;increment register 2Fh

```

Note that the “bank” instruction only modifies the upper three (not four) bits and always clears bit 4 in the FSR register. Therefore, to select an odd-numbered bank, you need to set bit 4 in the FSR register using a separate “set bit” instruction. For example, to increment file register 3Fh, you could use the following instructions:

```

bank $30    ;select Bank 3 in FSR (bits 7-6-5 only)
setb FSR.4  ;set bit 4 of FSR register to select Bank 3
inc  $1F    ;increment register 3Fh

```

After the FSR register has been set to the desired bank number, it is not necessary to set it again until you need to gain access to a different bank.

With indirect addressing, you specify the full 8-bit address of the register using FSR as a pointer. This addressing mode provides the flexibility to access different registers or multiple registers using the same instruction in the program.

You invoke indirect addressing by using fr=00h. For example:

```

mov  W,#$F5 ;load W with F5h
mov  FSR,W  ;move value F5h into FSR
mov  W,#$01 ;load W with 01h
mov  $00,W  ;move value 01h into register F5h

```

In the second “mov” instruction, FSR is loaded with the desired 8-bit register address. In the fourth “mov” instruction, fr = 00, so the device looks at FSR and moves the result to the register addressed by FSR, which is the register at F5h (Bank F, register number 5).

A practical example that uses indirect addressing is the following program, which clears the upper eight registers in the global register bank and all banks from Bank 1 through Bank F:

```

    clr   FSR           ;clear FSR to 00h (at address 04h)
:loop   setb FSR.3     ;set FSR bit 3
    clr   $00          ;clear register pointed to by FSR
    incszFSR          ;increment FSR and test, skip jmp if 00h
    jmp  :loop         ;jump back and clear next reg.

```

This program initially clears FSR to 00h. At the beginning of the loop, it sets bit 3 of FSR so that it starts at 08h. The “clr \$00” instruction clears the register pointed to by FSR (initially, the file register at 08h in the global register bank). Then the program increments FSR and clears consecutive file registers, always in the upper half of each bank: (08h, 09h, 0Ah ... 0Fh, 18h, 19h ... FFh). The loop ends when FSR wraps back to 00h.

For addresses from 01h through 0Fh, the global register bank is accessed. For higher addresses, Bank 1 through Bank F are accessed. This program does not affect Bank 0, which is not accessible in the indirect addressing mode. Bank 0 can be accessed only using the semi-direct mode.

2.4 Special-Function Registers

The SX instructions can access a set of dedicated file registers at the bottom of the data memory and the general-purpose file registers at higher addresses. Many instructions can also access certain non-memory-mapped registers: the Working register (W), the port control registers, the MODE register, and the OPTION register. All of these registers are eight bits wide.

[Table 2-2](#) lists and briefly describes the dedicated file registers and non-memory-mapped registers that are accessible to SX instructions.

2.4.1 W (Working Register)

The W register is the main working register used by many instructions as the source or destination of the operation. It is often used as a temporary storage area for intermediate operations. For example, to add the contents of two file registers, you must first move the contents of one file register to W and then execute an “add” instruction to perform an addition between W and the other file register.

In the default device configuration, W is not memory-mapped and can only be accessed by instructions that work specifically with W as the source or destination. However, you can optionally make the W available as a memory-mapped register at address 01h. To do this, first program the OPTIONX bit to 0 in the FUSE word in the program memory. Then have your program clear the RTW bit in the OPTION register. If you do this, the RTCC register normally at address 01h becomes unavailable.

2.4.2 INDF (Indirect through FSR)

The INDF register location (address 00h) is used for indirect addressing. Whenever this address is specified as the source or destination of an operation, the device uses the register pointed to by the FSR register (address 04h). There is no actual register or data stored at address 00h.

For more information on indirect addressing, see [Section 2.3](#).

Table 2-2 Register Summary

Register Name	Description
W	Working Register. This is the main working register used by many instructions as the source or destination of the operation.
INDF (00h)	Indirect through FSR. There is no actual register at this memory location. When this address (00h) is specified as the source or destination of an operation, the register location pointed to by FSR is accessed.
RTCC (01h)	Real-Time Clock/Counter. This register can be used to keep track of elapsed time or occurrences of transitions on the RTCC input pin.
PC (02h)	Program Counter. Only the lower eight bits of the program counter are available at this register location.
STATUS (03h)	Status. This register contains the status bits for the device such as the C bit, Z bit, and program memory page selection bits.
FSR (04h)	File Select Register. This register specifies the bank number for direct addressing or the full 8-bit address for indirect addressing.
RA (05h)	Port A Data Register. This register is used to control output signals and read input signals on the RA0-RA7 I/O pins.
RB (06h)	Port B Data Register. This register is used to control output signals and read input signals on the RB0-RB7 I/O pins.
RC (07h)	Port C Data Register. This register is used to control output signals and read input signals on the RC0-RC7 I/O pins. In devices without Port C, the register at 07h is a general-purpose register.
RD (08h)	Port D Data Register. This register is used to control output signals and read input signals on the RD0-RD7 I/O pins. In devices without Port D, the register at 08h is a general-purpose register.
RE (09h)	Port E Data Register. This register is used to control output signals and read input signals on the RE0-RE7 I/O pins. In devices without Port E, the register at 09h is a general-purpose register.
Port Control Registers	The port control registers are used to control the configuration of the port I/O pins. These registers are accessed by a special-purpose instruction, “mov !rx,W”.
MODE	MODE Register. This register controls access to the port control registers when you use the “mov !rx,W” instruction.
OPTION	Option Register. This register sets some device configuration options such as the Real-Time Clock/Counter incrementing mode.

2.4.3 RTCC (Real-Time Clock/Counter)

The RTCC register (address 01h) is an 8-bit Real-Time Clock/Counter used to keep track of elapsed time or to keep a count of transitions on the RTCC input pin. The timer operating configuration is determined by control bits in the OPTION register.

To keep track of time, you configure the timer register to be incremented once per instruction cycle or once per multiple of the instruction cycle. To count external events, you configure the timer register to be incremented once per rising edge or falling edge on the RTCC input pin.

The program can read or write the register at any time. A rollover from FFh to 00h generates an interrupt to the CPU if that condition is enabled as an interrupt.

For more information on the operation of the timer, see [Section 6.2](#).

If you do not need to use the RTCC register, you can optionally make the working register (W) available as a memory-mapped register at address 01h. For details, see the description of the W register.

2.4.4 PC (Program Counter)

The PC register (address 02h) contains the lower eight bits of the 11-bit or 12-bit program counter. The program counter is a pointer register that points to the current instruction being executed in the 2,048-word or 4,096-word program memory. During regular program execution, the program counter is incremented automatically once per instruction cycle. This regular sequence is altered in order to perform skips, jumps, and subroutine calls in the application program.

For detailed information on program counter operation, see [Section 2.6](#).

2.4.5 STATUS (Status Register)

The STATUS register (address 03h) contains the device status bits, which are automatically set or cleared by the device when certain events occur. The program can read this register at any time to determine the status of the device. The format of the register is shown below, and [Table 2-3](#) briefly describes each of the register bit fields.

PA2	PA1	PA0	TO	PD	Z	DC	C
Bit 7							Bit 0

The STATUS register is a read/write register except for the TO and PD bits, which are read-only bits. Those two bits cannot be changed by writing to the STATUS register address.

When you write to the STATUS register, it is recommended that you use the “setb” (set bit) and “clrb” (clear bit) instructions to control the individual bits rather than “mov” (move) instructions to move whole register values. This is because the CPU often modifies the STATUS register bits, possibly resulting in register values that are different from what you expect.

The individual bits of the STATUS register are described below.

Table 2-3 STATUS Register Bits

Status Bits	Description
PA2:PA0	Program memory page selection bits. You set or clear these bits to specify the program memory page number for a jump or call instruction.
TO	Watchdog timeout bit. This bit is set to 1 upon power-up and cleared to 0 when a Watchdog timeout occurs.
PD	Power Down bit. This bit is set to 1 upon power-up and cleared to 0 when the “SLEEP” instruction is executed.
Z	Zero bit. This bit is set when the result of an operation is zero.
DC	Digit Carry bit. This bit is set when there is a carry out from bit 3 to bit 4 in an addition operation and cleared when there is a borrow out from bit 3 to bit 4 in a subtraction operation.
C	Carry bit. This bit is set when there is a carry out of bit 7 in an addition operation and cleared when there is a borrow out of bit 7 a subtraction operation. It is also affected by the rotate-through-carry instructions.

PA2:PA0 (Program Memory Page Selection Bits)

PA2:PA0 are the program memory page selection bits. They are used to set the high-order bits of the program counter for jump and call instructions. You can set them without affecting the other bits in the STATUS register by using the “page” instruction. For details, see [Section 2.6](#).

T0 (Watchdog Timeout Bit)

T0 is the Watchdog Timeout bit. It is set to 1 upon power-up and cleared to 0 when a watchdog timeout occurs. It is set back to 1 upon execution of the “clrwdt” (clear Watchdog timer) instruction or “SLEEP” instruction. For details, see [Section 6.3](#).

PD (Power Down Bit)

PD is the Power Down bit. It is set to 1 upon power-up and cleared to 0 upon execution of the “SLEEP” instruction. It is set back to 1 upon execution of the “clrwdt” (clear Watchdog timer) instruction. For details, see [Section 4.3](#).

Z (Zero Bit)

Z is the Zero bit. This bit is affected by the execution of many types of instructions (add, subtract, increment, decrement, move, logic operations, and so on). When one of these instructions is executed, the Z bit is set to 1 if the result is zero or cleared to 0 if the result is nonzero.

DC (Digit Carry Bit)

DC is the digit carry bit. This bit is affected by the execution of instructions that add or subtract. For an instruction that performs addition, the C bit is set to 1 if a carry occurs out of bit 3 to bit 4, or is cleared to 0 otherwise. For instructions that perform subtraction, the C bit is cleared to 0 if a borrow occurs out of bit 3 to bit 4, or is set to 1 otherwise. This bit can be used to implement carry-bit functions with single hexadecimal digits.

C (Carry Bit)

C is the carry bit. This bit is affected by the execution of the addition, subtraction, and rotate-through-carry instructions. For an instruction that performs addition, the C bit is set to 1 if overflow occurs (a carry out of bit 7), or is cleared to 0 otherwise. For an instruction that performs subtraction, the C bit is cleared to 0 if underflow occurs (a borrow out of bit 7), or is set to 1 otherwise.

The device can be configured either to use or not use the C bit as an implicit input to addition and subtraction operations. This option is controlled by the \overline{CF} bit in the FUSEX Word (a word that is programmed at the same time as the program memory). An implicit addition of the C bit can be used to implement multiple-byte addition and subtraction algorithms.

In the default configuration, the carry bit is not used as an input to addition and subtraction operations. In that case, the carry bit can still be added or subtracted explicitly by using a separate “test carry bit and skip” instruction in conjunction with an “increment” or “decrement” instruction.

For rotate (RR or RL) instructions, the carry bit is loaded with the bit 0 or bit 7 respectively.

2.4.6 FSR (File Select Register)

The FSR register (address 04h) is the File Select Register used to specify the bank number for semi-direct addressing of file registers, or the full 8-bit address for indirect addressing of file registers. The file registers are addressed as follows:

- For semi-direct addressing, the high-order bits of FSR specify the bank number, and the instruction opcode specifies the register within the selected bank. The low-order bits of FSR are ignored in this addressing mode.
- For indirect addressing, the FSR register specifies the full 8-bit address of the register being accessed. To invoke this mode, the instruction specifies address 00h (INDF) as the source or destination of the operation.

For more information on using the FSR register for addressing the data registers, see [Section 2.3](#).

2.4.7 RA through RE (Port Data Registers)

The RA, RB, RC, RD, and RE registers (addresses 05h, 06h, 07h, 08h, and 09h) are the I/O port data registers for Port A through Port E. When a port is configured to operate as an output, writing to its port data register sets the output values of the port pins. In the default operating mode, reading from one of these register locations reads the port pins directly (not necessarily returning the values contained in the port data register).

For the SX48/52BD, a control bit called PORTRD in the T2CNT2 register determines how the device reads data from its I/O ports. Set this bit to 1 to have the device read data directly from the port I/O pins (the default operating mode). Clear this bit to 0 to have the device read data from the port data registers.

For detailed information on configuring and using the I/O ports, see [Chapter 5](#).

2.4.8 Port Control Registers and MODE Register

The MODE register controls access to the port control registers for subsequent uses of the “MOV !rx,W” instruction. For example, there are three registers for controlling Port A: the RA Direction register, the PLP_A (pullup enable A) register, and the LVL_A (level selection A) register. One of these three registers is accessed by the “mov !RA,W” instruction, depending on the value contained in the MODE register. For the SX48/52BD, use MODE values of 0Fh, 0Eh, or 0Dh, respectively to read the RA Direction, PLP_A, and LVL_A registers; or 1Fh, 1Eh, or 1Dh, respectively to write these same registers. On the SX18/20/28AC devices, the port control registers are write-only registers, and bit 4 of the MODE register is a “don’t care” bit.

Upon reset, the MODE register is initialized to 0Fh for the SX18/20/28AC or to 1Fh for the SX48/52BD. This makes the port direction registers write-accessible to the “MOV !rx,W” instructions. In order to access the other port control registers, you first need to write the appropriate value into the MODE register, as indicated in [Table 2-4](#) for the SX18/20/28AC or in [Table 2-5](#) for the SX48/52BD. MODE register values not listed in the tables are reserved for future expansion.

Table 2-4 MODE Register Settings for SX18/20/28AC

MODE Reg.	Register Written by mov !RA,W	Register Written by mov !RB,W	Register Written by mov !RC,W
X8h		Exchange CMP_B	
X9h		Exchange WKPND_B	
XAh		WKED_B	
XBh		WKEN_B	
XCh		ST_B	ST_C
XDh	LVL_A	LVL_B	LVL_C
XEh	PLP_A	PLP_B	PLP_C
XFh	RA Direction	RB Direction	RC Direction

Table 2-5 MODE Register Settings for SX48/52BD

MODE Reg.	mov !RA,W	mov !RB,W	mov !RC,W	mov !RD,W	mov !RE,W
00h		Read T1CPL	Read T2CPL		
01h		Read T1CPH	Read T2CPH		
02h		Read T1R2CML	Read T2R2CML		
03h		Read T1R2CMH	Read T2R2CMH		
04h		Read T1R1CML	Read T2R1CML		
05h		Read T1R1CMH	Read T2R1CMH		
06h		Read T1CNTB	Read T2CNTB		
07h		Read T1CNTA	Read T2CNTA		
08h		Exchange CMP_B			
09h		Exchange WKPND_B			
0Ah		Write WKED_B			
0Bh		Write WKEN_B			
0Ch		Read ST_B	Read ST_C	Read ST_D	Read ST_E
0Dh	Read LVL_A	Read LVL_B	Read LVL_C	Read LVL_D	Read LVL_E
0Eh	Read PLP_A	Read PLP_B	Read PLP_C	Read PLP_D	Read PLP_E
0Fh	Read RA Direction	Read RB Direction	Read RC Direction	Read RD Direction	Read RE Direction
10h		Clear Timer T1	Clear Timer T2		
11h					
12h		Write T1R2CML	Write T2R2CML		
13h		Write T1R2CMH	Write T2R2CMH		
14h		Write T1R1CML	Write T2R1CML		
15h		Write T1R1CMH	Write T2R1CMH		
16h		Write T1CNTB	Write T2CNTB		
17h		Write T1CNTA	Write T2CNTA		
18h		Exchange CMP_B			
19h		Exchange WKPND_B			
1Ah		Write WKED_B			
1Bh		Write WKEN_B			
1Ch		Write ST_B	Write ST_C	Write ST_D	Write ST_E
1Dh	Write LVL_A	Write LVL_B	Write LVL_C	Write LVL_D	Write LVL_E
1Eh	Write PLP_A	Write PLP_B	Write PLP_C	Write PLP_D	Write PLP_E
1Fh	Write RA Direction	Write RB Direction	Write RC Direction	Write RD Direction	Write RE Direction

After you write a value to the MODE register, that setting remains in effect until you change it by writing to the MODE register again. For example, you can write the value 1Eh to the MODE register just once, and then write to each of the three pullup configuration registers using the three “mov !rx,W” instructions shown at the top of [Table 2-4](#).

For detailed information on configuring and using the I/O ports, see [Chapter 5](#).

2.4.9 OPTION (Device Option Register)

The OPTION register sets several device configuration options, mostly related to operation of the Real-Time Clock/Counter. The format of the register is shown below. Upon reset, all bits in this register are set to 1.

RTW	RTE_IE	RTS	RTE_ES	PSA	PS2	PS1	PS0
Bit 7							Bit 0

RTW Bit: RTCC or W at address 01h

Clear the RTW bit to 0 to make W available as a memory-mapped register at address 01h. Set the RTW bit to 1 for the default register configuration, with RTCC at address 01h. Before you can clear the RTW bit, the option must be enabled by programming the $\overline{\text{OPTIONX}}$ bit to 0 in the FUSE word in the program memory.

RTE_IE Bit: RTCC Rollover Interrupt Enable

Clear the RTE_IE bit to 0 to enable the interrupt that occurs upon rollover of the RTCC counter, or set this bit to 1 to disable the interrupt. Before you can clear the RTE_IE bit, the option must be enabled by programming the $\overline{\text{OPTIONX}}$ bit to 0 in the FUSE word in the program memory.

RTS Bit: RTCC Trigger Selection

Clear the RTS bit to 0 to have the RTCC counter incremented automatically with each instruction cycle (or a specified number of instruction cycles). This mode can be used to implement a real-time clock. Set the RTS bit to 1 to have the RTCC counter incremented once each time a transition is detected on the RTCC input pin (or a specified number of transitions). This mode can be used as an external event counter.

RTE_ES: RTCC Input Edge Select

When the RTCC counter is configured to count transitions received on the RTCC pin (when RTS=1), the RTCC bit specifies the type of signal edges detected on the RTCC pin. Set RTE_ES to 1 to detect high-to-low transitions on the RTCC pin. Clear RTE_ES to 0 to detect low-to-high transitions on the RTCC pin.

PSA Bit: Prescaler Assignment

Clear the PSA bit to 0 to have the internal prescaler operate with the Real-Time Clock/Counter. In that case, the RTCC counter is incremented once every n instruction cycles, with the number n determined by the PS2:PS0 bits; and the Watchdog timer operates at the default rate.

Set the PSA bit to 1 to have the internal prescaler operate with the Watchdog timer. In that case, a Watchdog reset is generated after n timeouts of the Watchdog timer register, with the number n determined by the PS2:PS0 bits; and the RTCC register is incremented once per instruction cycle or external event.

PS2:PS0 Field: Prescaler Divide-By Factor

Use this bit field in conjunction with the PSA bit to specify an operating rate for the RTCC timer or Watchdog timer that is lower than the default rate. [Table 2-6](#) shows the clock divide-by factors determined by these bits. Note that for a given setting, the divide-by factor depends on whether you use the prescaler register with the RTCC timer (PSA=0) or with the Watchdog timer (PSA=1). For the RTCC timer, the timer is incremented once every 2, 4, 8, ... or 256 instruction cycles or external events. For the Watchdog timer, a Watchdog reset is triggered after 1, 2, 4, ... or 128 overflows of the Watchdog timer register.

Table 2-6 Prescaler Divide-By Factors

PS2:PS0	RTCC Timer Input Divide-By Factor (PSA=0)	Watchdog Timer Output Divide-By Factor (PSA=1)
000	2	1 (timeout = 0.018 sec)
001	4	2 (timeout = 0.037 sec)
010	8	4 (timeout = 0.073 sec)
011	16	8 (timeout = 0.15 sec)
100	32	16 (timeout = 0.29 sec)
101	64	32 (timeout = 0.59 sec)
110	128	64 (timeout = 1.17 sec)
111	256	128 (timeout = 2.34 sec)

For detailed information on the Real-Time Clock/Counter and Watchdog timer, see [Chapter 6](#).

2.5 Instruction Execution Pipeline

The CPU executes in program in a 4-stage pipeline consisting of the following stages:

- Fetch the instruction from program memory.
- Decode the instruction opcode.
- Execute the operation.
- Write the result to destination register.

Each execution stage requires one instruction cycle. Although it takes four cycles to complete the execution of each instruction, an overall throughput of one instruction per clock cycle is achieved by overlapping successive operations in the pipeline. For example, [Table 2-7](#) shows the sequence of operations carried out as the CPU executes the first six instructions of a program.

Table 2-7 Pipeline Execution Sequence

Program Instruction	Clock Cycle 1	Clock Cycle 2	Clock Cycle 3	Clock Cycle 4	Clock Cycle 5	Clock Cycle 6	etc.
1 st instruction	Fetch	Decode	Execute	Write			
2 nd instruction		Fetch	Decode	Execute	Write		
3 rd instruction			Fetch	Decode	Execute	Write	
4 th instruction				Fetch	Decode	Execute	...
5 th instruction					Fetch	Decode	...
6 th instruction						Fetch	...

As long as the normal flow of the program is not interrupted, the device performs four pipeline operations in parallel, thus achieving an overall throughput of one instruction per clock cycle, or 50 MIPS with a 50 MHz clock in the “turbo” clocking mode.

2.5.1 Clocking Modes

The SX device can be configured to operate in either the “turbo” or “compatible” mode. In the “turbo” mode, instructions are executed at the rate of one per clock cycle, and one clock cycle is the same as one instruction cycle. In the “compatible” mode, instructions are executed at the rate of one per four clock cycles, and four device clock cycles are required for each instruction cycle. For more information on these clocking modes, see [Section 4.2.1](#).

2.5.2 Pipeline Delays

Any instruction or interrupt condition that alters the normal program flow will take at least one additional instruction cycle. For example, when a test-and-skip instruction is executed and the tested condition is true, the next instruction in the program is skipped. The next instruction occupies space and takes up time in the pipeline whether or not it is skipped. As a result, a skipped instruction causes a delay of one instruction cycle when a skip occurs. The test-and-skip instruction is described as taking one cycle if the tested condition is false or two cycles if the tested condition is true.

The call, jump, and return-from-interrupt instructions reload the program counter and cause the program to jump to an entirely new location in program memory. As a result, the instructions in the pipeline are discarded, causing a multi-cycle delay in program execution. Each call, jump, and return-from-interrupt instruction takes two, three, or four cycles for execution, depending on the specific instruction and the device clocking mode. For details, see the instruction descriptions in [Chapter 3](#).

For the same reason, the triggering of an interrupt causes a pipeline delay. For an RTCC interrupt, the delay is three cycles. For a Multi-Input Wakeup interrupt, the delay is five cycles (two cycles for interrupt synchronization and a three-cycles pipeline delay).

2.5.3 Read-Modify-Write Considerations

A “read-modify-write” instruction is an instruction that operates by reading a register, modifying the value, and writing the result back to the register. Any instruction that writes a new value to a register that depends on the existing value is a read-modify-write instruction. Some examples are “clrb fr.bit” (clear bit), “setb fr.bit” (set bit), “add fr,w” (add W to file register), and “dec fr” (decrement file register). The “set bit” instruction, for example, does not simply set one bit and ignore the others. Instead, it reads the whole register, clears the specified bit, and writes the whole result back to the register.

When you use successive read-modify-write instructions on a port data register, you might get unexpected results at very high clock rates (such as 50 MHz). When you write to an I/O port, you write to the port data register; but when you read a port, you read the actual voltage on the I/O port pin (in the default operating mode). There is a slight delay from the time that the data port is written and the time that the output voltage changes to the programmed level.

When you use two successive read-modify-write instruction on the same I/O port, the “write” part of one instruction might not occur soon enough before the “read” part of the very next instruction, resulting in getting “old” data for the second instruction. (Remember that successive instructions are executed in parallel, one behind the next in the pipeline.)

To ensure predictable results, avoid using two successive read-modify-write instructions that access the same port data register. For example, you can insert a “nop” instruction between two such instructions in the program.

2.6 Program Counter

The program counter is an 11-bit or 12-bit register that points to the current instruction being executed in the 2,048-word or 4,096-word program memory (depending on the SX device type). The eight low-order bits of the program counter are directly accessible as a file register called the PC register, at address 02h. The higher-order bits are not directly accessible.

During regular program execution, the whole 11-bit or 12-bit program counter is incremented automatically once per instruction cycle. This regular sequence is altered in order to perform skips, jumps, subroutine calls, and interrupt processing.

Upon power-up or reset, the program counter is loaded with the highest program address (7FFh or FFFh). This memory location typically contains an instruction to jump to an initialization routine.

All interrupts cause the program counter to be loaded with 000h, the bottom program address. Therefore, if interrupts are used, the bottom memory segment must contain the interrupt service routine.

2.6.1 Test and Skip

There are several instructions that test a condition and cause the next instruction to be skipped if the condition is true. For example, the “SB fr.bit” instruction tests a bit in a file register and skips the next instruction if that bit is set to 1.

When a skip occurs, the program counter is incremented by two rather than one upon conclusion of the test-and-skip instruction, and the skipped instruction (which is already being processed in the pipeline) is canceled. There is a delay of one clock cycle caused by the skip operation.

2.6.2 Jump Absolute

The “JMP addr9” instruction causes the program to jump to a new location by loading a new value into the program counter. The lower nine bits of the new value come from a 9-bit field in the instruction opcode. The upper bits of the new value come from the PA2:PA0 bits of the STATUS register. Therefore, the PA2:PA0 bits of the STATUS register must be pre-loaded with the desired 512-word page number before the jump instruction is executed.

For example, if the jump destination is address 7E0h in the program memory, the PA2:PA0 bits in the STATUS register must be set to 011 before you execute the “JMP addr9” instruction. You can use the following sequence of instructions to perform the jump:

```
setb $03.5    ;set bit 5 in STATUS register (PA0)
setb $03.6    ;set bit 6 in STATUS register (PA1)
clrb $03.7    ;clear bit 7 in STATUS register (PA2)
jmp $1E0      ;jump to program memory address 7E0h
```

In this example, the desired jump address is 7E0h. The lower nine bits of this address are specified by the “JMP addr9” instruction as 1E0h, and the upper three bits are obtained from the PA2:PA0 bits (bits 7:5) in the STATUS register, which are set to 011 prior to the “jmp” instruction.

Another way to achieve the same effect faster and with fewer instructions is to use the “page” instruction to set the PA2:PA0 bits in the STATUS register:

```
page $600     ;set page to 600h (PA2:PA0 = 011 binary)
jmp $1E0      ;jump to program memory address 7E0h
```

The “page” instruction sets the values of the PA2:PA0 bits without affecting other bits in the STATUS register. It does this in just one clock cycle. You specify a 12-bit value in the instruction and the assembler encodes the three high-order bits of the value into the instruction (and ignores the lower-order bits). When you execute the instruction, it sets the PA2:PA0 bits in the STATUS register accordingly.

Note that it is necessary to set the PA2:PA0 bits prior to the “jmp” instruction only if they do not already contain the desired page number. You can set them just once and then use any number of “jmp” instructions as long as you stay within the same 512-word page in the program memory.

A “JMP addr9” instruction takes two clock cycles in the “compatible” clocking mode or three clock cycles in the “turbo” clocking mode. (For information on clocking modes, see [Section 4.2](#)).

2.6.3 Jump Indirect and Jump Relative

Instead of using the “JMP addr9” to specify an absolute jump destination, you can cause a jump by modifying the PC register (file register address 02h), which holds the lower eight bits of the program counter.

For example, to perform an indirect jump, you can move a new value from W to PC, as in the following example:

```
mov  W,$0B    ;load W with 8-bit jump address from file reg.
mov  $02,W    ;load PC with new address (lower 8 bits only)
```

To perform an indirect relative jump (a jump of a certain number of memory locations forward or backward from the next instruction), you can add W to PC or subtract W from PC, as in the following example:

```
mov  W,#$04   ;load W with the immediate value 04h
add  $02,W    ;increase PC by 4 (jump forward 5 instructions)
```

You can use an indirect jump to implement a multiple-branch conditional jump (for example, to jump to one of four different routines based on a calculation result).

If you perform a jump by modifying the PC register, you can only jump to a location within the same 256-word segment in the program memory. This is because you can only modify the lower eight bits of the program counter. To jump across a 256-word boundary, use the “PAGE addr12” and “JMP addr9” instructions.

A jump performed by modifying the PC register with a “mov” or “add” instruction takes four clock cycles in the “compatible” clocking mode or three clock cycles in the “turbo” clocking mode.

2.6.4 Call

The “CALL addr8” instruction calls a subroutine. It works just like a “JMP addr9” instruction, with the following differences:

- The “call” instruction saves the full program counter value, incremented by one, on the program stack. This allows the program to later return from the subroutine and continue execution with the instruction immediately following the call.
- The “call” instruction only specifies the lower eight bits (rather than the lower nine bits) of the jump address. The ninth bit (bit 8) of the jump address is always 0. Therefore, the subroutine must start in the bottom half of a 512-word page in the program memory (000h to 0FFh, 200h to 2FFh, etc.).

Figures 2-3 and 2-4 show how the program counter is loaded for a “jmp” instruction and for “call” instruction, respectively. In either case, the PA2:PA0 bits must contain the desired 512-word page of the program memory before the “jmp” or “call” instruction is executed. These bits can be easily changed with the “page” instruction.

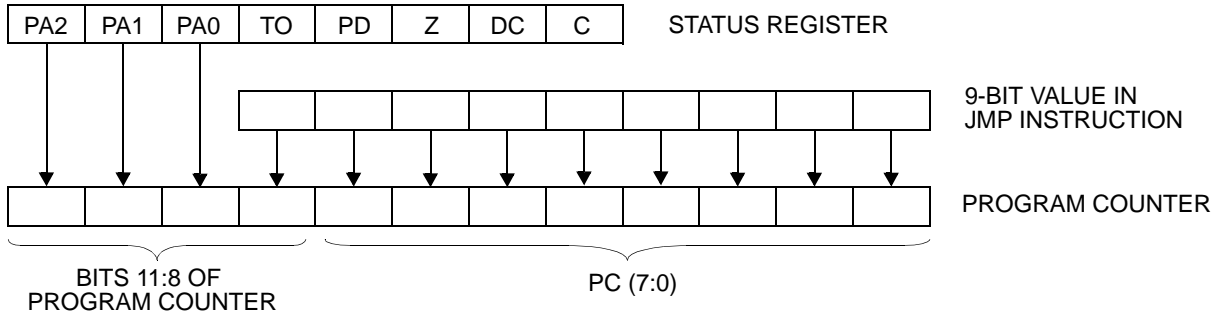

Figure 2-3 Program Counter Loading for Jump Instruction

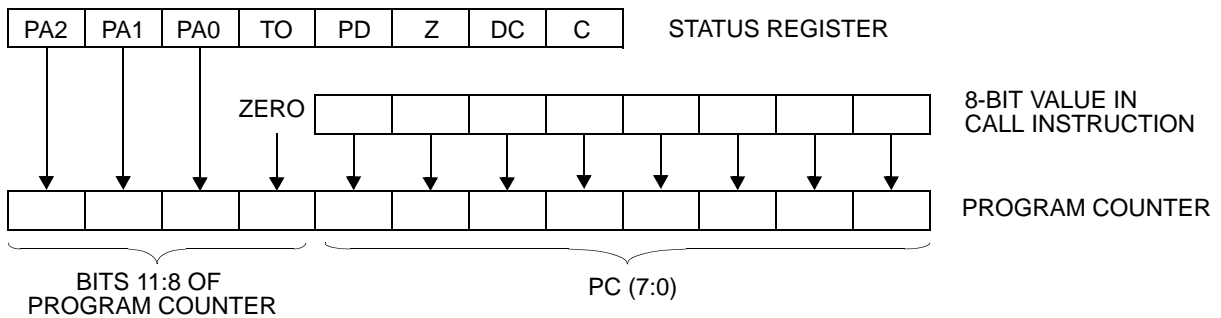

Figure 2-4 Program Counter Loading for Call Instruction

When a “call” instruction is executed, the CPU does the following:

- Increments the stack pointer and stores the full program counter contents on the program stack.
- Loads the lower eight bits of the program counter (the PC register) with the 8-bit value specified in the instruction opcode.
- Clears the ninth bit (bit 8) of the program counter to 0.
- Copies the PA2:PA0 bits into the high-order bit positions of the stack pointer (bits 11:9).

Like the “jmp” instruction, the “call” instruction takes two clock cycles in the “compatible” mode or three clock cycles in the “turbo” clocking mode.

2.6.5 Return

A subroutine called by the “call” instructions is terminated by a “return” instruction. The “return” instruction restores the full value to the program counter from the stack. This causes the program to jump back to the instruction immediately following the “call” instruction that called the subroutine.

It is not necessary to set the PA2:PA0 bits in the STATUS register in order to return to the correct place in the program. This is because the full program address is saved on the stack in a “call” instruction and fully restored by a “return” instruction. Therefore, the program always returns to the instruction

immediately following the “call” instruction, even for a subroutine call across page boundaries. The PA2:PA0 bits are ignored by “return” instructions.

There are several different “return” type instructions available in the instruction set. Some are for returning from subroutines and other are for returning from interrupts. All of them are listed and described in [Table 2-8](#). For more information on interrupts, see [Chapter 6](#).

Table 2-8 Return-from-Subroutine/Interrupt Instructions

Option Bits	Description
RET	Return from Subroutine. This is an ordinary return from subroutine. It does not affect any registers or bits.
RETP	Return from Subroutine Across Page Boundary. This instruction works like the RET instruction, but also writes bits 11:9 of the return address (the address of the instruction immediately following the CALL instruction) to the PA2:PA0 bits of the STATUS register. This automatically configures the PA2:PA0 bits to select the current page, allowing a subsequent same-page jump or call to be executed without another “page” instruction.
RETW #lit	Return from Subroutine with Literal in W. This instruction works like the RET instruction, except that it loads a literal value into W before returning from the subroutine. A sequence of these instructions can be used in conjunction with a PC-adjustment instruction to implement a data-lookup table.
RETI	Return from Interrupt. This instruction restores the program counter and the W, STATUS, and FSR registers that were saved upon occurrence of the interrupt. (Note that the program stack is not used for interrupt processing.)
RETIW	Return from Interrupt and Adjust RTCC with W. This instruction works like the RETI instruction, but also adds W to the RTCC register. This can be used to adjust the RTCC counter back to the value in contained upon occurrence of the interrupt.

2.7 Stack

When a “call” instruction is executed, the full address of the instruction immediately following the “call” instructions is pushed onto the program stack. Upon return from the subroutine, the full address is popped from the stack and restored to the program counter, causing execution to resume with the instruction immediately following the “call” instruction.

The stack is a last-in, first-out (LIFO) data buffer, 12 bits wide (11 bits wide for the SX18/20/28AC) and eight levels deep. The eight levels of the stack allow subroutines be nested, one within another, up to eight levels deep.

In the default device configuration, the stack is limited to two levels. In general, however, the stack should be configured to eight levels because there is no reason to limit the stack size. This option is

controlled by the $\overline{\text{STACKX}}$ bit in the FUSE word register (a register programmed at the same time as the program memory).

The stack is not memory-mapped and there are no “push” or “pop” instructions in the instruction set. Therefore, the program stack is not directly accessible to the program and is not used for any purpose other than to save and restore program memory addresses, which is done implicitly by “call” and “return” instructions.

There is no “stack pointer” for this stack. Instead, the device simply moves all the data words down or up the stack for each “call” or “return” instruction executed, as indicated in Figures 2-5 and 2-6.

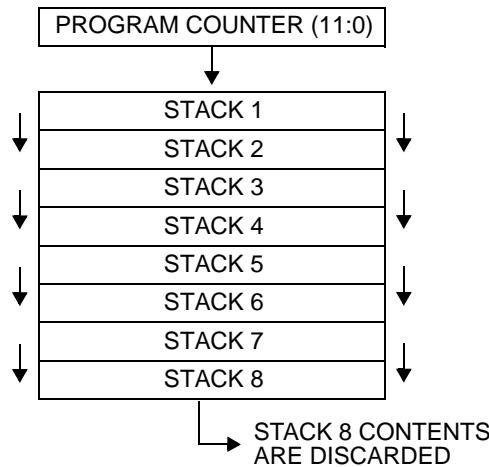

Figure 2-5 Stack Operation for a “Call” Instruction

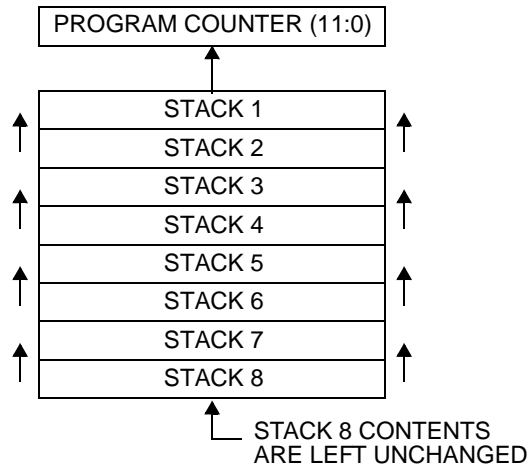

Figure 2-6 Stack Operation for a “Return” Instruction

For a “call” instruction, the device copies the contents of the whole program counter to the top stack location, and existing words in the stack are moved down by one stack location. Any data word in the bottom stack location is lost.

For any type of return-from-subroutine instruction (RET, RETP, or RETW lit), the device copies the contents of the top-level stack location into the program counter, and existing words in the stack are moved up by one stack location. The bottom stack location is left unchanged.

If you attempt to nest subroutines beyond eight levels, or if you execute a return-from-subroutine instruction without a prior corresponding “call” instruction, unpredictable results will occur because an incorrect address will be copied to the program counter.

The stack is not used for interrupt processing and is therefore not involved in the return-from-interrupt instructions (RETI and RETIW). For information on interrupt processing, see [Chapter 6](#).

2.8 Device Configuration Options

The SX device has three 12-bit configuration registers that can be read or written at the same time that the instruction memory is programmed:

- FUSE word register, memory-mapped in the program memory at FFFh (SX18/20/28AC) or 1FFFh (SX48/52BD)
- FUSEX word register, accessible by a device programming command
- DEVICE word register, a read-only word accessible by a device programming command

These registers are not accessible to the application program at run time. They can only be read or written when the device is set up for programming the instruction memory.

The register formats are shown in [Figure 2-7](#) and the configuration fields within the registers are explained in [Table 2-9](#), [Table 2-10](#), [Table 2-11](#) and [Table 2-12](#). Note that the format of the FUSEX register depends on the SX device type (SX18/20/28AC or SX48/52BD).

FUSE Word for SX18/20/28AC (Read/Program at FFFh in main memory map)

$\overline{\text{TURBO}}$	$\overline{\text{SYNC}}$	Reserved	Reserved	$\overline{\text{IRC}}$	$\overline{\text{DIV1/IFBD}}$	$\overline{\text{DIV0/FOSC2}}$	Reserved	$\overline{\text{CP}}$	WDTE	FOSC1	FOSC0	
Bit 11												Bit 0

FUSE Word for SX48/52BD (Read/Program at 1FFFh in main memory map)

$\overline{\text{TURBO}}$	$\overline{\text{SYNC}}$	$\overline{\text{OPTIONX}}$	$\overline{\text{STACKX}}$	$\overline{\text{IRC}}$	DIV2	DIV1	DIV0	$\overline{\text{CP}}$	WDTE	FOSC1	FOSC0	
Bit 11												Bit 0

FUSEX Word for SX18/20/28AC

IRCTRIM2	PINS	IRCTRIM1	IRCTRIM0	$\overline{\text{OPTIONX/STACKX}}$	$\overline{\text{CF}}$	BOR1	BOR0	BORTRIM1	BORTRIM0	BP1	BP0	
Bit 11												Bit 0

FUSEX Word for SX48/52BD

SLEEPCLK	WDRT2	WDRT1	WDRT0	$\overline{\text{CF}}$	IRCTRIM2	IRCTRIM1	IRCTRIM0	Res.	Res.	BOR1	BOR0	
Bit 11												Bit 0

DEVICE Word (Hard-Wired Read-Only)

Part ID Code: FFEh for the SX18/20/28AC or 001h for the SX48/52BD												
Bit 11												Bit 0

Figure 2-7 Device Configuration Register Formats

Table 2-9 FUSE Word Register Configuration Bits for SX18/20/28AC (Sheet 1 of 2)

Option Bits	Description
$\overline{\text{TURBO}}$	Turbo Mode. Set to 1 for “compatible” mode, in which the instruction rate operates at one-fourth the oscillator clock rate. Set to 0 for the turbo mode, in which the instruction rate is equal to the oscillator clock rate.
$\overline{\text{SYNC}}$	Synchronous Input Mode (for turbo mode operation). Set to 1 to disable or clear to 0 to enable. This bit allows an input signal to be synchronized with internal clock through two internal flip-flops.
$\overline{\text{IRC}}$	Internal RC Oscillator. Set to 1 to disable the internal oscillator and have the OSC1 and OSC2 pins operate as defined by the FOSC2:FOSC0 bits. Clear to 0 to enable the internal oscillator, and to have the OSC1 pin pulled low by weak pull-up and the OSC2 pin pulled high by weak pullup.
DIV2:DIV0	Internal RC Oscillator Divider. This field sets the divide-by factor for generating the instruction clock from the internal oscillator when the internal oscillator is enabled ($\overline{\text{IRC}} = 0$). The nominal instruction rate is determined by DIV2:DIV0 as follows: 00 = 4 MHz 01 = 1 MHz 10 = 128 KHz 11 = 32 KHz
$\overline{\text{IFBD}}$	Internal Feedback Disable. If $\overline{\text{IRC}} = 1$, and $\overline{\text{IFBD}} = 1$, the crystal/resonator oscillator can rely on the internal feedback resistor between the OSC1 and OSC2 pins. If $\overline{\text{IFBD}} = 0$, an external feedback resistor is required between the OSC1 and OSC2 pins.
$\overline{\text{CP}}$	Code Protection. Set to 1 for no code protection. Clear to 0 for code protection. With code protection, the program code and configuration registers read back as scrambled data. This prevents reverse-engineering of your proprietary code and configuration options.

Table 2-9 FUSE Word Register Configuration Bits for SX18/20/28AC (Sheet 2 of 2)

Option Bits	Description
WDTE	Watchdog timer enable. Set to 1 to enable the Watchdog timer. Clear to 0 to disable the Watchdog timer.
FOSC1: FOSC0	External Oscillator Configuration. This combination of three register bits sets up the device to operate with a particular type of external oscillator when the device is configured to operate with an external oscillator ($\overline{IRC} = 1$). Note that bit 5, the DIV0/FOSC2 bit, operates as DIV0 with $\overline{IRC}=0$, or as FOSC2 with $\overline{IRC}=1$. The type of external oscillator is determined by FOSC2:FOSC0 as follows: 000 = LP1 – low-power crystal (32 KHz) 001 = LP2 – low-power crystal (32 KHz to 1 MHz) 010 = XT1 – low-power crystal (32 KHz to 10 MHz) 011 = XT2 – normal crystal (1 MHz to 24 MHz) 100 = HS – normal crystal (1 MHz to 50 MHz) 101 = Reserved 110 = Reserved 111 = External RC Note: The frequency ranges have not been characterized. These are target values.

Table 2-10 FUSEX Word Register Configuration Bits for SX18/20/28AC

Option Bits	Description
PINS	Selects the number of pins.
IRCTRIM2: IRCTRIM	Internal RC Oscillator Trim. This 3-bit field adjusts the operation of the internal RC oscillator to make it operate within the target frequency range of 4.0 MHz plus or minus 8%. Parts are shipped from the factory untrimmed. The device relies on the programming tool to provide the trimming function. 000b = minimum frequency 111b = maximum frequency
$\overline{OPTIONX}$ / \overline{STACKX}	OPTION Register Extension and Stack Extension. Set to 1 to disable the programmability of bit 6 and bit 7 in the OPTION register, the RTW and RTE_IE bits (in other words, to force these two bits to 1); and to limit the program stack size to two locations. Clear to 0 to enable programming of the RTW and RTE_IE bits in the OPTION register, and to extend the stack size to eight locations.
\overline{CF}	Carry bit Input. Set to 1 to ignore the carry bit as an input to addition and subtraction operations. Clear to 0 to add the carry bit into all addition operations (ADD fr,W means $fr = fr + W + C$); and to subtract the complement of the carry bit from all subtraction operations (SUB fr,W means $fr = fr - W - /C$).

**Table 2-10** FUSEX Word Register Configuration Bits for SX18/20/28AC

Option Bits	Description
BOR1: BOR0	Brown-Out Reset. The BOR1:BOR0 bits enable or disable the brown-out reset function and set the brown-out threshold voltage as follows: 00 = 4.2V 01 = 2.6V 10 = 2.2V 11 = Disable Brown-Out Reset
BORTRIM1: BORTRIM0	Brown-Out trim bits (parts are shipped out of the factory untrimmed).
BP1: BP0	Configured Memory Size. These two factory-configured bits should not be changed unless you want to reduce the configured amount of program memory in the device. To do so, use one the following BP1:BP0 settings: 00 = 1 page, 1 bank 01 = 1 page, 2 banks 10 = 4 pages, 4 banks 11 = 4 pages, 8 banks (default)

Table 2-11 FUSE Word Register Configuration Bits for SX48/52BD

Option Bits	Description
$\overline{\text{TURBO}}$	Turbo Mode. Set to 1 for “compatible” mode, in which the instruction rate operates at one-fourth the oscillator clock rate. Set to 0 for the turbo mode, in which the instruction rate is equal to the oscillator clock rate.
$\overline{\text{SYNC}}$	Synchronous Input Mode (for turbo mode operation). Set to 1 to disable or clear to 0 to enable synchronous inputs.
$\overline{\text{OPTIONX}}$	OPTION Register Extension. Set to 1 to disable the programmability of bit 6 and bit 7 in the OPTION register, the RTW and RTE_IE bits (in other words, to force these two bits to 1). Clear to 0 to enable programming of the RTW and RTE_IE bits in the OPTION register.
$\overline{\text{STACKX}}$	Stack Extension. Set to 1 to limit the stack size to two locations. Clear to 0 to extend the stack size to eight locations.
$\overline{\text{IRC}}$	Internal RC Oscillator. Set to 1 to disable the internal oscillator and have the OSC1 and OSC2 pins operate as defined by the FOSC1:FOSC0 bits. Clear to 0 to enable the internal oscillator, and to have the OSC1 pin floating and the OSC2 pin weakly pulled high.

Table 2-11 FUSE Word Register Configuration Bits for SX48/52BD

Option Bits	Description
DIV2:DIV0	<p>Internal RC Oscillator Divider. This field sets the divide-by factor for generating the instruction clock from the internal oscillator when the internal oscillator is enabled ($\overline{IRC} = 0$). The nominal instruction rate is determined by DIV2:DIV0 as follows:</p> <ul style="list-style-type: none"> 000 = 4 MHz 001 = 2 MHz 010 = 1 MHz 011 = 500 kHz 100 = 250 kHz 101 = 125 kHz 110 = 62.5 kHz 111 = 31.25 kHz
\overline{CP}	<p>Code Protection. Set to 1 for no code protection. Clear to 0 for code protection. With code protection, the program code and configuration registers read back as scrambled data. This prevents reverse-engineering of your proprietary code and configuration options.</p>
WDTE	<p>Watchdog timer enable. Set to 1 to enable the Watchdog timer. Clear to 0 to disable the Watchdog timer.</p>
FOSC1: FOSC0	<p>External Oscillator Configuration. This field sets up the device to operate with a particular type of external oscillator when the device is configured to operate with an external oscillator ($\overline{IRC} = 1$). The type of external oscillator is determined by FOSC1:FOSC0 as follows:</p> <ul style="list-style-type: none"> 00 = LP – low-power crystal 01 = HS – high-speed crystal 10 = XT – normal crystal 11 = RC network – OSC2 is weakly pulled high and no CLKOUT output

**Table 2-12** FUSEX Word Register Configuration Bits for SX48/52BD

Option Bits	Description
SLEEPCLK	Sleep Clock Disable. Clear this bit to 0 to enable operation of the clock during power down mode (to allow fast start-up). Set this bit to 1 to disable clock operation during power down mode (to reduce power consumption).
WDRT2: WDRT0	<p>Delay Reset Timer (DRT) timeout period. This 3-bit field can be used to specify the DRT timeout period that results in an automatic wake-up from the power down mode:</p> <p>100 = 0 msec (no delay) 101 = 0.06 msec 110 = 7.68 msec 111 = 18.4 msec (default) 000 = 60 msec 001 = 480 msec 010 = 960 msec 011 = 1920 msec</p> <p>For fast start-up from the power down mode, clear the SLEEPCLK bit and set the WDRT2:WDRT0 field to 100. This will keep the clock operating during the power down mode and allow a zero start-up delay.</p>
$\overline{\text{CF}}$	Carry Bit Input. Set to 1 to ignore the carry bit as an input to addition and subtraction operations. Clear to 0 to add the carry bit into all addition operations (ADD fr,W means $fr = fr + W + C$); and to subtract the complement of the carry bit from all subtraction operations (SUB fr,W means $fr = fr - W - /C$).
IRCTRIM2: IRCTRIM	Internal RC Oscillator Trim. This 3-bit field adjusts the operation of the internal RC oscillator to make it operate within the target frequency range of 4.0 MHz plus or minus 8%. Parts are shipped from the factory untrimmed. The device relies on the programming tool to provide the trimming function.
BOR1: BOR0	Brown-Out Reset; factory preset values. Bits should not be changed unless brown-out feature is to be disabled. Set bits to “11b” to disable.



Chapter 3

Instruction Set

3.1 Introduction

The Scenix SX microcontrollers use a RISC (Reduced Instruction Set Computer) architecture. In this type of architecture, the instruction set is limited in complexity and diversity, but the instructions can be executed very fast, typically at a rate of one instruction per clock cycle. High performance is achieved by executing many simple instructions very fast.

The instruction set consists entirely of single-word (12-bit) instructions, most of which can be executed at a rate of one instruction per clock cycle, for a total throughput of up to 50 MIPS (million instructions per second) when the device operates with a 50 MHz clock. The only common instructions that take more than one clock cycle to execute are those that control program flow, such as call and return instructions, and test-and-skip instructions that result in a skip.

3.2 Instruction Operands

An SX program consists of a sequence of instructions stored in the device program memory. Each instruction, when executed, changes the data contained in one or more device registers. All data registers are eight bits wide.

Most of the device registers are memory-mapped. Each memory-mapped register occupies an address in the data memory address space, and can be accessed by the “mov” instructions of the SX instruction set. An instruction refers to a memory-mapped register by specifying a 5-bit “fr” (file register) value in the instruction. Multiple sets or “banks” of registers are available, as specified by the File Select Register (FSR). For more information on register addressing modes, see [Section 2.3](#).

The W (Working) register is used in many of the instructions but is not memory-mapped. It is often used as the source or destination of an operation. The letter “W” represents this register in the syntax of the assembly language.

There are several dedicated-purpose registers and many general-purpose registers in the data memory address space, organized as described in Chapter 2. The exact number of registers and their organization depend on the specific SX device type.

The source data for an operation can be provided by the instruction opcode itself rather than a register. An operand provided this way is called an “immediate” operand. In the syntax of the assembly language, the “number” or “pound” character (#) indicates an immediate value. Here is one example:

```
mov W,#$0F ;move immediate value 0Fh into W
```

The immediate value 0Fh is loaded into the W register. The 8-bit immediate value occupies an eight-bit field in the instruction opcode.

3.3 Instruction Types

The instructions are divided into the following categories:

- Logic Instructions
- Arithmetic and Shift Instructions
- Bitwise Operation Instructions
- Data Movement Instructions
- Program Control Instructions
- System Control Instructions

The following subsections describe the characteristics of the instructions in these categories.

3.3.1 Logic Instructions

Each logic instruction performs a standard logical operation (AND, OR, exclusive OR, or logical complement) on the respective bits of the 8-bit operands. The result of the logic operation is written to W or to a file register.

All of these instructions take one clock cycle for execution.

3.3.2 Arithmetic and Shift Instructions

Each arithmetic or shift instruction performs an operation such as add, subtract, rotate left or right through carry, increment, decrement, clear to zero, or swap high/low nibbles.

The device can be configured either to use or not use the carry bit as an implicit input to addition and subtraction operations. This option is controlled by the \overline{CF} bit in the FUSEX Word (a word that is programmed at the same time as the program memory). In the default configuration, the carry bit is not used as an input to these operations. In that case, the carry bit can still be added or subtracted explicitly by using a separate “test carry bit” instruction in conjunction with an “increment” or “decrement” instruction.

There are instructions available that increment or decrement a register and simultaneously test the result. If the 8-bit result is zero, the next instruction in the program is skipped. These instructions can be used to make program loops.

All of the arithmetic and shift instructions take one clock cycle for execution, except in the case of the test-and-skip instructions when the tested condition is true and a skip occurs.

3.3.3 Bitwise Operation Instructions

There are four bitwise operation instructions:

- “setb” sets a single bit to 1 in a data register without affecting other bits
- “clrb” clears a single bit to 0 in a data register without affecting other bits
- “sb” tests a single bit in a data register and skips the next instruction if the bit is set to 1
- “snb” tests a single bit in a data register and skips the next instruction if the bit is cleared to 0

Any bit in any memory-mapped register can be set, cleared, or tested individually, including bits in the program counter, FSR register, and STATUS register. These instructions are often used to set, clear, and test bits in the STATUS register.

All of the bitwise operation instructions take one clock cycle for execution, except in the case of the test-and-skip instructions when the tested condition is true and a skip occurs. If a skip instruction is immediately followed by a PAGE or BANK instruction (and the tested condition is true) then two instructions are skipped and the operation consumes three cycles. This is useful for conditional branching to another page where a PAGE instruction precedes a JMP. If several PAGE and BANK instructions immediately follow a skip instruction then they are all skipped plus the next instruction and a cycle is consumed for each.

3.3.4 Data Movement Instructions

Each data movement instruction moves a byte of data from one register to another, or performs an operation on the contents of a source register and simultaneously moves the result into W (without affecting the source register). The following operations can be performed simultaneously with data movement into W: add, subtract, complement, increment, decrement, rotate left, rotate right, and swap high/low nibbles.

Instructions are also available that simultaneously increment or decrement the contents of a register, move the result into W, and test the result. If the 8-bit result is zero, the next instruction in the program is skipped.

Additional data movement instructions are provided to access the port control registers, the MODE register, and the OPTION register, which are not accessible as ordinary file registers.

All of the data movement instructions take one clock cycle for execution, except in the case of the test-and-skip instructions when the tested condition is true and a skip occurs.

3.3.5 Program Control Instructions

Each program control instruction alters the flow of the program by changing the contents of the program counter. Included in this category are the jump, call, and return-from-subroutine instructions.

The “jmp” instruction has a single operand that specifies the new address at which to resume execution. The new address is typically specified as a label, as in the following example:

```
snb STATUS.0      ;check carry bit and skip next if C=0
jmp do_carry      ;jump to do_carry routine if C=1
...
do_carry          ;jump destination label
...              ;program execution continues here
```

If the carry bit is set to 1, the “jmp” instruction is executed and program execution continues where the “do_carry” label appears in the program.

The “call” instruction works in a similar manner, except that it saves the contents of the program counter before jumping to the new address. Therefore, it calls a subroutine that can be terminated by any of several “return” instructions, as shown in the following example:

```
...
call add_2bytes   ;call subroutine add_carry
...              ;subroutine results used here
add_2bytes       ;subroutine label
...              ;subroutine code here
ret              ;return from subroutine
```

Returning from a subroutine restores the saved program counter contents, which causes program to resume execution with the instruction immediately following the “call” instruction.

A program memory address contains 12 bits (or 11 bits for the SX18/20/28AC). The “jmp” instruction specifies only the lowest nine bits of the jump address and the “call” instruction specifies only the lowest eight bits of the call address. For information on how the device handles the higher-order program address bits, see [Section 2.6](#).

An indirect (register-specified) jump can be accomplished by moving the desired jump address from W to the PC register (mov \$02,W). An indirect relative jump can be accomplished by adding W to the PC register (add \$02,W).

Program control instructions such as “jmp,” “call,” and “ret” alter the normal program sequence. Therefore, when one of these instructions is executed, the execution pipeline is automatically cleared of pending instructions and refilled with new instructions, starting at the new program address. Because the pipeline must be cleared, multiple clock cycles are required for execution. The typical execution time for one of these instructions is two or three clock cycles, depending on the specific instruction and the device configuration mode (“compatible” or “turbo” clocking mode). For the exact number of clock cycles required, see the instruction set summary tables or the detailed instruction descriptions.

3.3.6 System Control Instructions

A system control instruction performs a special-purpose operation that sets the operating mode of the device or reads data from the program memory. Included in this category are the following instructions:

- “bank” loads a bank number into the FSR register
- “iread” reads a word from the program memory

- “page” writes the page number bits in the STATUS register
- “sleep” places the device in the power down mode

All of these instructions take one clock cycle for execution, except in the case of the “iread” instruction in the “turbo” device clocking mode, which takes four clock cycles.

3.4 Instruction Summary Tables

Tables 3-1 through 3-6 list all of the SX instructions, organized by category. For each instruction, the table shows the instruction mnemonic (as written in assembly language), a brief description of what the instruction does, the number of instruction cycles required for execution, the binary opcode, and the status Bits affected by the instruction.

The “Cycles” column typically shows a value of 1, which means that the overall throughput for the instruction is one per clock cycle. In some cases, the exact number of cycles depends on the outcome of the instruction (such as the test-and-skip instructions) or the clocking mode (Compatible or Turbo). In those cases, all possible numbers of cycles are shown in the table.

The instruction execution time is derived by dividing the oscillator frequency by either one (Turbo mode) or four (Compatible mode). The divide-by factor is selected through the FUSE Word register

The detailed instruction descriptions in Section 3.5 fully explain the operation of each instruction, including the Bits affected, the number of cycles required for execution, and usage examples.

Table 3-1 Logic Instructions

Syntax	Description	Cycles		Opcode	Bits
		Comp.	Turbo		
AND fr, W	AND of fr and W into fr	1	1	0001 011f ffff	Z
AND W, fr	AND of W and fr into W	1	1	0001 010f ffff	Z
AND W,#lit	AND of W and Literal into W	1	1	1110 kkkk kkkk	Z
NOT fr	Complement of fr into fr	1	1	0010 011f ffff	Z
OR fr,W	OR of fr and W into fr	1	1	0001 001f ffff	Z
OR W,fr	OR of W and fr into fr	1	1	0001 000f ffff	Z
OR W,#lit	OR of W and Literal into W	1	1	1101 kkkk kkkk	Z
XOR fr,W	XOR of fr and W into fr	1	1	0001 101f ffff	Z
XOR W,fr	XOR of W and fr into W	1	1	0001 100f ffff	Z
XOR W,#lit	XOR of W and Literal into W	1	1	1111 kkkk kkkk	Z

Table 3-2 Arithmetic and Shift Instructions (Sheet 1 of 2)

Syntax	Description	Cycles		Opcode	Bits
		Comp.	Turbo		
ADD fr,W	Add W to fr	1	1	0001 111f ffff	C, DC, Z
ADD W,fr	Add fr to W	1	1	0001 110f ffff	C, DC, Z
CLR fr	Clear fr	1	1	0000 011f ffff	Z
CLR W	Clear W	1	1	0000 0100 0000	Z
CLR !WDT	Clear Watchdog Timer	1	1	0000 0000 0100	TO, PD
DEC fr	Decrement fr	1	1	0000 111f ffff	Z
DECSZ fr	Decrement fr and Skip if Zero	1 or 2 (skip)	1 or 2 (skip)	0010 111f ffff	none
INC fr	Increment fr	1	1	0010 101f ffff	Z
INCSZ fr	Increment fr and Skip if Zero	1 or 2 (skip)	1 or 2 (skip)	0011 111f ffff	none
RL fr	Rotate fr Left through Carry	1	1	0011 011f ffff	C

Table 3-2 Arithmetic and Shift Instructions (Sheet 2 of 2)

Syntax	Description	Cycles		Opcode	Bits
		Comp.	Turbo		
RR fr	Rotate fr Right through Carry	1	1	0011 001f ffff	C
SUB fr,W	Subtract W from fr	1	1	0000 101f ffff	C, DC, Z
SWAP fr	Swap High/Low Nibbles of fr	1	1	0011 101f ffff	none

Table 3-3 Bitwise Operation Instructions

Syntax	Description	Cycles		Opcode	Bits
		Comp.	Turbo		
CLRB fr.bit	Clear Bit in fr	1	1	0100 bbbf ffff	none
SB fr.bit	Test Bit in fr and Skip if Set	1 or 2 (skip)	1 or 2 (skip)	0111 bbbf ffff	none
SETB fr.bit	Set Bit in fr	1	1	0101 bbbf ffff	none
SNB fr.bit	Test Bit in fr and Skip if Clear	1 or 2 (skip)	1 or 2 (skip)	0110 bbbf ffff	none

Table 3-4 Data Movement Instructions (Sheet 1 of 2)

Syntax	Description	Cycles		Opcode	Bits
		Comp.	Turbo		
MOV fr,W	Move W to fr	1	1	0000 001f ffff	none
MOV W,fr	Move fr to W	1	1	0010 000f ffff	Z
MOV W,fr-W	Move (fr-W) to W	1	1	0000 100f ffff	C, DC, Z
MOV W,#lit	Move Literal to W	1	1	1100 kkkk kkkk	none
MOV W,/fr	Move Complement of fr to W	1	1	0010 010f ffff	Z
MOV W,--fr	Move (fr-1) to W	1	1	0000 110f ffff	Z
MOV W,++fr	Move (fr+1) to W	1	1	0010 100f ffff	Z

Table 3-4 Data Movement Instructions (Sheet 2 of 2)

Syntax	Description	Cycles		Opcode	Bits
		Comp.	Turbo		
MOV W,<<fr	Rotate fr Left through Carry and Move to W	1	1	0011 010f ffff	C
MOV W,>>fr	Rotate fr Right through Carry and Move to W	1	1	0011 000f ffff	C
MOV W,<>fr	Swap High/Low Nibbles of fr and move to W	1	1	0011 100f ffff	none
MOV W,M	Move MODE Register to W	1	1	0000 0100 0010	none
MOVSZ W,--fr	Move (fr-1) to W and Skip if Zero	1 or 2 (skip)	1 2 (skip)	0010 110f ffff	none
MOVSZ W,++fr	Move (fr+1) to W and Skip if Zero	1 or 2 (skip)	1 2 (skip)	0011 110f ffff	none
MOV M,W	Move W to MODE Register	1	1	0000 0100 0011	none
MOV M,#lit	Move Literal to MODE Register	1	1	0000 0101 kkkk	none
MOV !rx,W	Move W to Port Rx Control Register	1	1	0000 0000 ffff	none
MOV !OPTION, W	Move W to OPTION Register	1	1	0000 0000 0010	none
TEST fr	Test fr for Zero	1	1	0010 001f ffff	Z

Table 3-5 Program Control Instructions

Syntax	Description	Cycles		Opcode	Bits
		Comp.	Turbo		
CALL addr8	Call Subroutine	2	3	1001 kkkk kkkk	none
JMP addr9	Jump to Address	2	3	101k kkkk kkkk	none
NOP	No Operation	1	1	0000 0000 0000	none
RET	Return from Subroutine	2	3	0000 0000 1100	none
RETP	Return from Subroutine Across Page Boundary	2	3	0000 0000 1101	PA1, PA0
RETI	Return from Interrupt	2	3	0000 0000 1110	all Status
RETIW	Return from Interrupt and Add RTCC to W	2	3	0000 0000 1111	all Status
RETW lit	Return from Subroutine with Literal in W	2	3	1000 kkkk kkkk	none

Table 3-6 System Control Instructions

Syntax	Description	Cycles		Opcode	Bits
		Comp.	Turbo		
BANK addr8	Load Bank Number into FSR(7:5)	1	1	0000 0001 1nnn	none
IREAD	Read Word from Instruc- tion Memory	1	4	0000 0100 0001	none
PAGE addr12	Load Page Number into STATUS(7:5)	1	1	0000 0001 0nnn	PA2, PA1, PA0
SLEEP	Power Down Mode	1	1	0000 0000 0011	TO, PD

3.5 Equivalent Assembler Mnemonics

Some assemblers support additional instruction mnemonics that are special cases of existing instructions or alternative mnemonics for standard ones. For example, an assembler might support the mnemonic “CLC” (clear carry), which is interpreted the same as the instruction “clrb \$03.0” (clear bit 0 in the STATUS register). Some of the commonly supported equivalent assembler mnemonics are described in [Table 3-7](#).

Table 3-7 Equivalent Assembler Mnemonics

Syntax	Description	Equivalent	Cycles
CLC	Clear Carry Bit	CLRB \$03.0	1
CLZ	Clear Zero Bit	CLRB \$03.2	1
JMP W	Jump Indirect W	MOV \$02,W	4 or 3 (note 1)
JMP PC+W	Jump Indirect W Relative	ADD \$02,W	4 or 3 (note 1)
MODE imm4	Move Immediate to MODE Register	MOV M,#lit	1
NOT W	Complement W	XOR W,#\$FF	1
SC	Skip if Carry Bits Set	SB \$03.0	1 or 2 (note 2)
SKIP	Skip Next Instruction	SNB \$02.0 or SB \$02.0	4 or 2 (note 3)
<p>NOTES: 1. The JMP W or JMP PC+W instruction takes 4 cycles in the “compatible” clocking mode or 3 cycles in the “turbo” clocking mode.</p> <p>2. The SC instruction takes 1 cycle if the tested condition is false or 2 cycles if the tested condition is true.</p> <p>3. The assembler converts the SKIP instruction into a SNB or SB instruction that tests the least significant bit of the program counter, choosing SNB or SB so that the tested condition is always true. The instruction takes 4 cycles in the “compatible” clocking mode or 2 cycles in the “turbo” clocking mode.</p>			

3.6 Detailed Instruction Descriptions

Each instruction in the SX instruction set is described in detail in the following pages. The instructions are described in alphabetical order by mnemonic name.

Each description starts on a new page of the manual. The heading at the top of the page shows the syntax of the command and a brief description of what the command does.

In the syntax description, the parts that are to be used literally are shown in upper case and the variable parts are shown in lower case. For example, the “add W to file register” command is shown as follows:

ADD fr,W

The “ADD” and “W” should be used exactly as shown in the command syntax, whereas the lower-case notation “fr” means that you should use a file register address, which can be any value from \$00 to \$1F, or an equivalent symbol. In an actual program, you can use either upper-case or lower-case characters. Here is an example of an actual “add W to register” command:

```
add $0F,W ;add contents of W to file register 0Fh
```

The text after the semicolon is a comment, which is ignored by the assembler.

Each instruction description includes the following information:

- **Operation.** This section describes the effects of the command in equation form. For example, the “add W to file register” command shows the operation as “fr = fr + W” (fr is set equal to the sum of fr plus W).
- **Bits affected.** This is a list of the status bits that are affected by execution of the command, such as the carry (C) and zero (Z) bits.
- **Opcode.** This is the 12-bit opcode of the encoded instruction, shown in binary format. Bits that depend on variables are shown as letters rather than 0 or 1. For example, the opcode for the “ADD fr,W” instruction is shown as 0001 110f ffff. The sequence of five “f” characters represents the five-bit file register address specified in the instruction. The letter “k” or “n” is similarly used to represent the constant or number specified in the instruction.
- **Description.** This is a verbal description of what the instruction does.
- **Cycles.** This is the number of clock cycles required to execute the instruction. In cases where this number depends on certain conditions, those conditions and the resulting numbers are explained. In some cases, the number depends on the clocking mode (“turbo” or “compatible” mode). In the “compatible” mode, the number shown is the number of regular instruction cycles required for execution, each cycle consisting of four device clocks.
- **Example.** At least one example of the instruction is provided, together with an explanation of how the example operates.

In some cases, there is an additional section called “Config. Option,” which explains how the behavior of the instruction is affected by the device configuration.

Some assemblers support additional instruction mnemonics that are special cases of existing instructions. Also, some assemblers support “macro” mnemonics, which are assembled into multiple instructions. These additional assembler mnemonics are beyond the scope of this section. For more information, see the documentation provided with the assembler.

[Table 3-8](#) is a quick reference to the abbreviations and symbols used in the instruction descriptions.

Table 3-8 Key to Abbreviations and Symbols

Symbol	Description
W	Working register
fr	File register value (a 5-bit file register address specified in the instruction)
PC	Lower eight bits of program counter (global file register 02h)
STATUS	STATUS register (global file register 03h)
FSR	File Select Register (global file register 04h)
C	Carry bit in STATUS register (bit 0)
DC	Digit Carry bit in STATUS register (bit 1)
Z	Zero bit in STATUS register (bit 2)
PD	Power Down bit in STATUS register (bit 3)
TO	Watchdog Timeout bit in STATUS register (bit 4)
PA2:PA0	Page select bits in STATUS register (bits 7:5)
OPTION	OPTION register (not memory-mapped)
WDT	Watchdog Timer register (not memory-mapped)
MODE	MODE register (not memory-mapped)
rx	Port control register pointer (RA, RB, RC, RD, or RE)
!	Non-memory-mapped register designator
f	File register address bit in opcode
k	Constant value bit in opcode
n	Numerical value bit in opcode
b	Bit position selector bit in opcode
.	File register / bit selector separator in assembly language instruction
#	Immediate literal designator in assembly language instruction
lit	Literal value in assembly language instruction
addr8	8-bit address in assembly language instruction
addr9	9-bit address in assembly language instruction
addr12	12-bit address in assembly language instruction
/	Logical 1's complement
	Logical OR
^	Logical exclusive OR
&	Logical AND
<>	Swap high and low nibbles (4-bit segments)
<<	Rotate left through carry bit
>>	Rotate right through carry bit
--	Decrement file register
++	Increment file register

3.6.1 ADD fr,W**Add W to fr**Operation: $fr = fr + W$

Bits affected: C, DC, Z

Opcode: 0001 111f ffff

Description: This instruction adds the contents of W to the contents of the specified file register and writes the 8-bit result into the same file register. W is left unchanged. The register contents are treated as unsigned values.

If the result of addition exceeds FFh, the C bit is set and the lower eight bits of the result are written to the file register. Otherwise, the C bit is cleared.

If there is a carry from bit 3 to bit 4, the DC (digit carry) bit is set. Otherwise, the bit is cleared.

If the result of addition is 00h, the Z bit is set. Otherwise, the bit is cleared. An addition result of 100h is considered zero and therefore sets the Z bit.

Config. Option: If the \overline{CF} bit in the FUSEX configuration register has been programmed to 0, this instruction also adds the C bit as a carry-in input:

$$fr = fr + W + C$$

Cycles: 1

Example: `add $12,W`

This example adds the contents of W to file register 12h. For example, if the file register contains 7Fh and W contains 02h, this instruction adds 02h to 7Fh and writes the result, 81h, into the file register; and clears the C and Z bits. It sets the DC bit because of the carry from bit 3 to bit 4.

3.6.2 ADD W,fr

Add fr to W

Operation: $W = W + fr$

Bits affected: C, DC, Z

Opcode: 0001 110f ffff

Description: This instruction adds the contents of the specified file register to the contents of W and writes the 8-bit result into W. The file register is left unchanged. The register contents are treated as unsigned values.

If the result of addition exceeds FFh, the C bit is set and the lower eight bits of the result are written to W. Otherwise, the C bit is cleared.

If there is a carry from bit 3 to bit 4, the DC (digit carry) bit is set. Otherwise, the bit is cleared.

If the result of addition is 00h, the Z bit is set. Otherwise, the bit is cleared. An addition result of 100h is considered zero and therefore sets the Z bit.

Config. Option: If the \overline{CF} bit in the FUSEX register has been programmed to 0, this instruction also adds the C bit as a carry-in input:

$$W = W + fr + C$$

Cycles: 1

Example: `add W,$12`

This example adds the contents of file register 12h to W. For example, if the file register contains 81h and W contains 82h, this instruction adds 81h to 82h and writes the lower eight bits of the result, 03h, into W. It sets the C bit because of the carry out of bit 7, and clears the DC bit because there is no carry from bit 3 to bit 4. The Z bit is cleared because the result is nonzero.

3.6.3 AND fr,W

AND of fr and W into fr

Operation: $fr = fr \& W$

Bits affected: Z

Opcode: 0001 011f ffff

Description: This instruction performs a bitwise logical AND of the contents of the specified file register and W, and writes the 8-bit result into the same file register. W is left unchanged. If the result is 00h, the Z bit is set.

Cycles: 1

Example: `and $10,W ;perform logical AND and overwrite fr`

This example performs a bitwise logical AND of the working register W with a value stored in file register 10h. The result is written back to the file register 10h.

For example, suppose that the file register 10h is loaded with the value 0Fh and W contains the value 13h. The instruction takes the logical AND of 0Fh and 13h and writes the result, 03h, into the same file register. The result is nonzero, so the Z bit is cleared.

3.6.4 AND W,fr

AND of W and fr into W

Operation: $W = W \& fr$

Bits affected: Z

Opcode: 0001 010f ffff

Description: This instruction performs a bitwise logical AND of the contents of W and the specified file register, and writes the 8-bit result into W. The file register is left unchanged. If the result is 00h, the Z bit is set.

Cycles: 1

Example: `and W,$0B ;perform logical AND and overwrite W`

This example performs a bitwise logical AND of the value stored in file register 0Bh with W. The result is written back to W.

For example, suppose that the file register 0Bh is loaded with the value 0Fh and W contains the value 13h. The instruction takes the logical AND of 0Fh and 13h and writes the result, 03h, into W. The result is nonzero, so the Z bit is cleared.

3.6.5 AND W,#lit

AND of W and Literal into W

Operation: $W = W \& \text{lit}$

Bits affected: Z

Opcode: 1110 kkkk kkkk

Description: This instruction performs a bitwise logical AND of the contents of W and an 8-bit literal value, and writes the 8-bit result into W. If the result is 00h, the Z bit is set.

Cycles: 1

Example: `and W,#$0F ;mask out four high-order bits of W`

This example performs a bitwise logical AND of W with the literal value #0Fh. The result is written back to W.

For example, suppose that W contains the value 50h. The instruction takes the logical AND of this value with 0Fh and writes the result, 00h, into W. The result is zero, so the Z bit is set.

3.6.6 BANK addr8

Load Bank Number into FSR(7:5)

Operation: FSR(7:5) = addr8(7:5)
FSR(4) = 0 (for SX48/52BD only)

Bits affected: none

Opcode: 0000 0001 1nnn

Description: This instruction loads the three high-order bits of the File Select Register (FSR). The high-order bits of FSR specify the data memory bank number for subsequent memory access instructions. You can specify any 3-bit value from 0 to 7.

In the syntax of the assembly language, you specify the bank using a full 8-bit data memory address. The assembler encodes the three high-order bits of this address into the instruction opcode and ignores the five low-order bits.

For the SX18/20/28AC, the bits 4:0 of FSR are left unchanged.

For the SX48/52BD, bit 4 is cleared to 0 and bits 3:0 of FSR are left unchanged. To select an odd-numbered bank, you need to set bit 4 of FSR by using the instruction “setb \$04.4” after the “bank” instruction.

If a skip instruction is immediately followed by BANK instruction (and tested condition is true) then two instructions are skipped and the operation consumes three cycles. This is useful for conditional branching to another page where a PAGE instruction precedes a JMP. If several BANK instructions immediately follow a skip instruction then they are skipped plus the next instruction and a cycle is consumed for each.

Cycles: 1

Example: bank \$E0 ;select highest bank

This example writes the three high-order bits of FSR with 111. For the SX18/20/28A, this selects Bank 7, the highest bank. For the SX48/52BD, this selects Bank E, because the instruction always clears bit 4 in the FSR register. To select Bank F instead, you need to follow this instruction with a “setb \$04.4” instruction.

3.6.7 CALL addr8**Call Subroutine**

Operation: top-of-stack = program counter + 1
 PC(7:0) = addr8
 program counter (8) = 0
 program counter (11:9) = PA2:PA0

Bits affected: none

Opcode: 1001 kkkk kkkk

Description: This instruction calls a subroutine. The full 12-bit address of the next program instruction is saved on the stack and the program counter is loaded with a new address, which causes a jump to that program address.

Bits 7:0 come from the 8-bit constant value in the instruction, bit 8 is always 0, and bits 11:9 come from the PA2:PA0 bits in the STATUS register. Therefore, the subroutine must start in the bottom half of a 512-word page in the program memory (000h to 0FFh, 200h to 2FFh, etc.).

The subroutine is terminated by any one of the “return” instructions, which restores the saved address to the program counter. Execution proceeds from the instruction following the “call” instruction.

Cycles: 2 in “compatible” mode, or 3 in “turbo” mode

```
Example:  page    $600      ;set page of subroutine in STATUS reg.
          call    addxy    ;call subroutine addxy
          mov    $0C,W     ;use addxy subroutine results
          ...           ;more of program (not shown)
          addxy                   ;subroutine address label
          mov    W,$0E     ;subroutine instructions start here
          add    W,$0F
          ...
          ret              ;return from subroutine
```

The “call” instruction in this example calls a subroutine called “addxy.” When the “call” instruction is executed, the address of the following instruction (the “mov \$0C,W” instruction) is pushed onto the stack and the program jumps to the “addxy” routine. When the “ret” instruction is executed, the 12-bit program address saved on the stack is popped and restored to the program counter, which causes the

program to continue with the instruction immediately following the “call” instruction.

The “addxy” routine must start in the lower half of a 512-word page of the program memory. This is because bit 8 of the subroutine address must be 0. The PA2:PA0 bits of the STATUS register must contain the three high-order bits of the subroutine address prior to the “call” instruction. This is the purpose of the “page” instruction.

3.6.8 CLR fr**Clear fr**

Operation: fr = 0

Bits affected: Z

Opcode: 0000 011f ffff

Description: This instruction clears the specified file register to zero. It also sets the Z bit unconditionally.

Cycles: 1

Example: clr \$0A

This example clears file register 0Ah to 00h and sets the Z bit.

3.6.9 CLR W**Clear W**

Operation: W = 0

Bits affected: Z

Opcode: 0000 0100 0000

Description: This instruction clears W, the working register. It also sets the Z bit.

Cycles: 1

Example: clr W

This example clears W to 00h and sets the Z bit.

3.6.10 CLR !WDT**Clear Watchdog Timer**

Operation: Clears Watchdog timer counter and prescaler counter

Bits affected: Z

Opcode: 0000 011f ffff

Description: This instruction clears the Watchdog Timer counter to zero. It also clears the Watchdog prescaler register to zero, and sets the Z, TO, and PD bits to 1 (the Zero, Watchdog Timeout, and Power Down bits in the STATUS register).

If the Watchdog circuit is enabled, the application software must execute this instruction periodically in order to prevent a Watchdog reset.

Cycles: 1

Example: `clr !WDT`

This example clears the Watchdog Timer counter and the Watchdog prescaler register to zero; and sets the Z, TO, and PD bits.

3.6.11 CLRb fr.bit**Clear Bit in fr**

Operation: Clear a specified bit in fr

Bits affected: none

Opcode: 0100 bbbf ffff

Description: This instruction clears a bit in the specified file register to 0 without changing the other bits in the register. The file register address (00h through 1Fh) and the bit number (0 through 7) are the instruction operands.

Cycles: 1

Example: `clrb $1F.7`

This example clears the most significant bit of file register 1Fh.

3.6.12 DEC fr**Decrement fr**

Operation: $fr = fr - 1$

Bits affected: Z

Opcode: 0000 111f ffff

Description: This instruction decrements the specified register file by one.

If the file register contains 01h, it is decremented to 00h and the Z bit is set. Otherwise, the bit is cleared.

If the file register contains 00h, it is decremented to FFh.

Cycles: 1

Example: dec \$18

This example decrements file register 18h.

3.6.13 DECSZ fr**Decrement fr and Skip if Zero**

Operation: $fr = fr - 1$
 if 0, then skip next instruction

Bits affected: none

Opcode: 0010 111f ffff

Description: This instruction decrements the specified register file by one and tests the new register value. If that value is zero, the next program instruction is skipped. Otherwise, execution proceeds normally with the next instruction.

Cycles: 1 if tested condition is false, 2 if tested condition is true

Example: `decsz $18`
 `jmp back1`
 `mov $19,W`

The “decsz” instruction decrements file register 18h. If the result is nonzero, execution proceeds normally with the “jmp” instruction. If the result is zero, the device skips the “jmp” instruction and proceeds with the “mov” instruction.

3.6.14 INC fr**Increment fr**

Operation: $fr = fr + 1$

Bits affected: Z

Opcode: 0010 101f ffff

Description: This instruction increments the specified register file by one.

If the file register contains FFh and is incremented to 00h, the Z bit is set. Otherwise, the bit is cleared.

Cycles: 1

Example: `inc $18`

This example increments file register 18h.

3.6.15 INCSZ fr**Increment fr and Skip if Zero**

Operation: $fr = fr + 1$
 if 0, then skip next instruction

Bits affected: none

Opcode: 0011 111f ffff

Description: This instruction increments the specified register file by one and tests the new register value. If that value is zero, the next program instruction is skipped. Otherwise, execution proceeds normally with the next instruction.

Cycles: 1 if tested condition is false, 2 if tested condition is true

Example: incsz \$18
 jmp back1
 mov \$17,W

The “incsz” instruction increments file register 18h. If the result is nonzero, execution proceeds normally with the “jmp” instruction. If the result is zero, the device skips the “jmp” instruction and proceeds with the “mov” instruction.

3.6.16 IREAD**Read Word from Instruction Memory**

Operation: $\text{MODE:W} = \text{data at (MODE:W)}$

Bits affected: none

Opcode: 0000 0100 0001

Description: This instruction allows the device to transfer data from instruction memory into data memory. It concatenates the lower four bits of the MODE register with W to make a 12-bit address, using the MODE register bits for the high-order part and W for the low-order part. It reads the 12-bit word from program memory at that address. Then it writes the four high-order bits of the word into the lower four bits of the MODE register, and writes the eight low-order bits of the word into W. The four high-order bits of the MODE register are cleared to zero.

Figure 3-1 shows how the MODE and W register are used to specify the program memory address and to contain the 12-bit result.

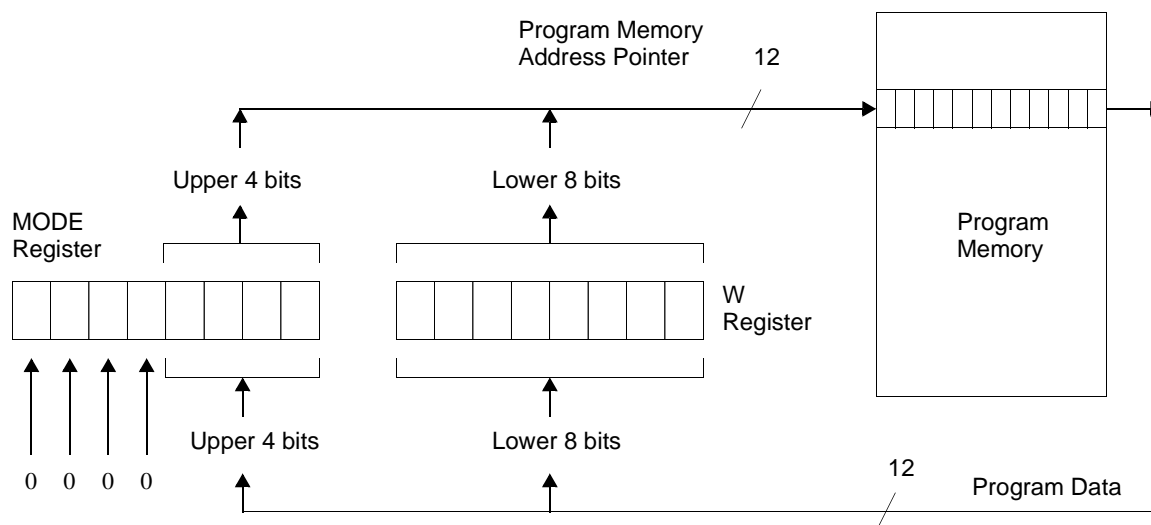

Figure 3-1 Program Counter Loading for Call Instruction

Cycles: 1

Example:

mov	W,#\$03	;load W with the value 03h
mov	M,W	;move value 03h into MODE register
mov	W,#\$80	;load W with the value 80h
iread		;read program address 380h into W & MODE
mov	\$0E,W	;move lower byte of data to reg 0Eh
mov	W,M	;move upper 4 bits of data to W
mov	\$0F,W	;move upper 4 bits of data to reg 0Fh

This example reads the 12-bit data stored the program address 380h. The program first loads the MODE register and W with the 12-bit program address, 380h. After the “iread” instruction, the MODE register and W contain the 12-bit value stored in the program memory at address 380h. The program then stores the lower eight bits of the result into file register 0Eh and the upper four bits of the result into file register 0Fh.

3.6.17 JMP addr9**Jump to Address**

Operation: PC(7:0) = addr9(7:0)
 program counter (8) = addr9(8)
 program counter (11:9) = PA2:PA0

Bits affected: none

Opcode: 101k kkkk kkkk

Description: This instruction causes the program to jump to a specified address. It loads the program counter with the new address. The new 12-bit address is generated from two different sources. Bits 8:0 come from the 9-bit constant value in the instruction and bits 11:9 come from the PA2:PA0 bits in the STATUS register. The STATUS register must contain the appropriate value prior to the jump instruction.

Cycles: 2 in “compatible” mode, or 3 in “turbo” mode

```
Example:        page    $600        ;set page of jump addr. in STATUS reg.
                  snb    $03.0     ;test carry bit and skip if clear
                  jmp    overflo    ;jump to overflo routine if C=1
                  ...               ;more of program (not shown)
                  overflo         ;
                  mov    W,$09     ;routine executed if C=1
                  ...
```

This example shows one way to implement a conditional jump. The “jmp” instruction, if executed, causes a jump to the address of the “overflo” program label. The “snb” instruction (test bit and skip if clear) causes the “jmp” instruction to be either executed or skipped, depending on the state of the carry bit.

The PA2:PA0 bits of the STATUS register must contain the three high-order bits (bits 11:9) of the “overflo” routine address prior to the “jump” instruction. This is the purpose of the “page” instruction.

3.6.18 MOV fr,W**Move W to fr**

Operation: fr = W

Bits affected: none

Opcode: 0000 001f ffff

Description: This instruction moves the contents of W into the specified file register. W is left unchanged.

Cycles: 1

Example: bank \$E0 ;select bank
mov \$10,W ;move W to reg. 10h in bank

This example moves the contents of W into file register 10h in Bank 7 (for the SX18/20/28AC) or Bank E (for the SX48/52BD).

3.6.19 MOV M,#lit**Move Literal to MODE Register**

Operation: MODE = lit

Bits affected: none

Opcode: 0000 0101 kkkk

Description: This instruction writes a 4-bit value to the lower four bits of the MODE register. These bits select the port control registers accessed by the “MOV !rx,W” instructions. For information on the specific MODE register values to use for accessing the port control registers, see [Section 5.3.2](#).

Cycles: 1

Example: mov W,#\$1D ;1Dh to control level sensitivity
 mov M,W ;put 1Dh into MODE register
 mov W,#\$00 ;W = 0000 0000
 mov !RA,W ;select CMOS levels for Port A
 mov M,\$E ;1Eh to control pullups
 mov W,\$03 ;W = 0000 1111
 mov !RA,W ;disconnect pullups for RA3:RA0
 mov M,\$F ;1Fh to control data direction
 mov W,\$0F ;W = 1111 0000
 mov !RA,W ;make RA3:RA0 operate as outputs

This example sets the configuration of Port A pins: the level sensitivity, the pullup connections, and the data direction. The “mov M,W” instruction is used to load the MODE register the first time because it controls all eight bits of the MODE register. The two subsequent “mov M,#lit” instructions change the lower four bits of the MODE register.

3.6.20 MOV M,W**Move W to MODE Register**

Operation: MODE = W

Bits affected: none

Opcode: 0000 0100 0011

Description: This instruction moves the contents of W into the MODE register. W is left unchanged. The MODE register operates as a pointer to the port control registers for subsequent accesses to those registers using the “MOV !rx,W” instruction.

Cycles: 1

Example: mov W,\$0B ;move value from file reg 0Bh to W
 mov M,W ;move W into MODE register

This example moves a value from file register 0Bh to W, and then from W into the MODE register.

3.6.21 MOV !OPTION,W**Move W to OPTION Register**

Operation: OPTION = W

Bits affected: none

Opcode: 0000 0000 0010

Description: This instruction moves W to the OPTION register. W is left unchanged. The OPTION register sets the Real-Time Clock/Counter (RTCC) configuration options such as RTCC interrupt enable, RTCC increment event control, and prescaler assignment. For information on the format of the OPTION register, see [Section 2.4.9](#).

Cycles: 1

Example: mov W,#\$3F ;load W with 3Fh
 mov !OPTION,W ;write value to OPTION register

This example moves programs the OPTION register with the value 3Fh.

3.6.22 MOV !rx,W

Move Data Between W and Control Register

Operation: rx = W (move W to rx) *or*
 W = rx (move rx to W) *or*
 rx <=> W (exchange W and rx)

Bits affected: none

Opcode: 0000 0000 ffff

Description: This instruction moves data between W and one of the port control registers (rx). The port control register is specified in the instruction mnemonic as !RA, !RB, !RC, !RD, or !RE. This corresponds to a 4-bit field in the opcode that is set to 5, 6, 7, 8 or 9 to access a port control register for Port A, B, C, D, or E, respectively.

To access the port data register rather than a port control register, use the “MOV fr,W” or similar instruction, addressing the port as “fr” rather than “!rx”.

Each port has a set of control registers: one each for setting the data direction, the pullup configuration, the Schmitt trigger configuration, and so on. The MODE register setting determines the port control register accessed by the “MOV !rx,W” instruction, as well as the type of access (read, write, or exchange).

For information on the specific MODE register values to use for accessing the port control registers, see [Section 5.3.2](#).

Cycles: 1

```
Example 1:  mov    W,#$1F    ;1Fh to select data direction
            mov    M,W      ;write 1Fh to MODE register
            mov    W,#$3F    ;pins 0-5 Hi-Z inputs, pins 6-7 outputs
            mov    !RB,W     ;configure Port B pin data directions
            mov    W,#$FF    ;all pins Hi-Z inputs
            mov    !RC,W     ;configure Port C pin data directions
```

This example configures the data direction for each pin of Port B and Port C. The first two instructions program the MODE register to allow access to the port data direction registers. The third instruction loads W with the value 3Fh. The fourth instruction writes this value to the RB direction register, which configures pins 0 through 5 to operate as high-impedance inputs and pins 6 and 7 to operate as outputs. The last two instructions configure all Port C pins to operate as inputs.



Example 2:

```
mov    M,$8      ;load MODE register to select CMP_B
clr    W          ;clear W
mov    !RB,W     ;00h into CMP_B and old CMP_B into W
                    ;enables comparator and its output pin
```

This example enables the comparator and its output pin. The “mov !RB,W” instruction does an exchange of data between the CMP_B register and W. For access to the CMP_B register, the four upper bits of the MODE register are all “don’t care” bits, so the “mov M,#lit” instruction (which only affects the four lower bits of the MODE register) is sufficient to select access to the CMP_B register.

3.6.23 MOV W,fr**Move fr to W**

Operation: W = fr

Bits affected: Z

Opcode: 0010 000f ffff

Description: This instruction moves the contents of the specified file register into W. The file register is left unchanged.

If the value is 00h, the Z bit is set. Otherwise, the bit is cleared.

Cycles: 1

Example: bank \$E0 ;select bank
 mov W,\$1F ;move register to W

This example moves the contents of a specific file register into W. The Z bit is set if the value is zero or cleared if the value is nonzero.

3.6.24 MOV W,fr**Move Complement of fr to W**

Operation: $W = fr \wedge FFh$

Bits affected: Z

Opcode: 0000 000f ffff

Description: This instruction loads the one's complement of the specified file register into W. The file register is left unchanged.

If the value loaded into W is 00h, the Z bit is set. Otherwise, the bit is cleared.

Cycles: 1

Example: `mov W,/$0F`

This example moves the one's complement of global file register 0Fh into W. For example, if the file register contains 75h, the complement of this value, 8Ah, is loaded into W, and the Z bit is cleared. The file register is left unchanged.

3.6.25 MOV W,fr-W**Move (fr-W) to W**

Operation: $W = fr - W$

Bits affected: C, DC, Z

Opcode: 0000 100f ffff

Description: This instruction subtracts the contents of W from the contents of the specified file register and writes the 8-bit result into W. The file register is left unchanged. The register contents are treated as unsigned values.

If the result of subtraction is negative (W is larger than fr), the C bit is cleared to 0 and the lower eight bits of the result are written to W. Otherwise, the C bit is set to 1.

If there is a borrow from bit 3 to bit 4, the DC (digit carry) bit is cleared to 0. Otherwise, the bit is set to 1.

If the result of subtraction is 00h, the Z bit is set. Otherwise, the bit is cleared.

Config. Option: If the \overline{CF} bit in the FUSEX configuration register has been programmed to 0, this instruction also subtracts the complement of the C bit as a borrow-in input:

$$W = fr - W - /C$$

Cycles: 1

Example: `mov W,$0D-W`

This example subtracts the contents of W from global file register 0Dh and moves the result into W. For example, if the file register contains 35h and W contains 06h, this instruction subtracts 06h from 35h and writes the result, 2Fh, into W. It also sets the C bit, clears the DC bit, and clears the Z bit. The file register is left unchanged.

3.6.26 MOV W,--fr**Move (fr-1) to W**Operation: $W = fr - 1$

Bits affected: Z

Opcode: 0000 110f ffff

Description: This instruction decrements the value in the specified register file by one and moves the 8-bit result into W. The file register is left unchanged.

If the file register contains 01h, the value moved into W is 00h and the Z bit is set. Otherwise, the bit is cleared.

Cycles: 1

Example: `mov w,--$18`

This example decrements the value in file register 18h and moves the result into W. For example, if the file register contains 75h, the value 74h is loaded into W, and the Z bit is cleared. The file register still contains 75h after execution of the instruction.

3.6.27 MOV W,++fr**Move (fr+1) to W**

Operation: $W = fr + 1$

Bits affected: Z

Opcode: 0010 100f ffff

Description: This instruction increments the value in the specified register file by one and moves the 8-bit result into W. The file register is left unchanged.

If the file register contains FFh, the value moved into W is 00h and the Z bit is set. Otherwise, the bit is cleared.

Cycles: 1

Example: `mov w,++$18`

This example increments the value in file register 18h and moves the result into W. For example, if the file register contains 75h, the value 76h is loaded into W, and the Z bit is cleared. The file register still contains 75h after execution of the instruction.

3.6.28 MOV W,<<fr**Rotate fr Left through Carry and Move to W**Operation: $W = \ll fr$

Bits affected: C

Opcode: 0011 010f ffff

Description: This instruction rotates the bits of the specified file register left using the C bit and moves the 8-bit result into W. The file register is left unchanged.

The bits obtained from the register are shifted left by one bit position. C is shifted into the least significant bit position and the most significant bit is shifted out into C, as shown in the diagram below.

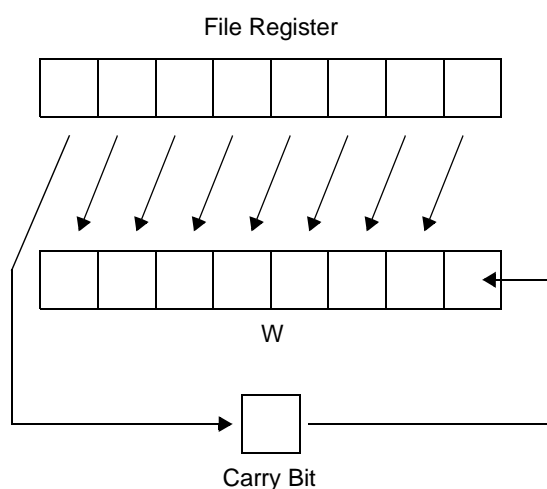
**Figure 3-2** Rotate fr Left Through Carry into W

Cycles: 1

Example 1: `mov W,<<$18`

This example rotates the bits of file register 18h left through the C bit and moves the result into W. If the file register contains 14h and the C bit is set to 1, after this instruction is executed, W will contain 29h and the C bit will be cleared to 0. The file register will still contain 14h after execution of the instruction.

3.6.29 MOV W,>>fr

Rotate fr Right through Carry and Move to W

Operation: W = >> fr

Bits affected: C

Opcode: 0011 000f ffff

Description: This instruction rotates the bits of the specified file register right using the C bit and moves the 8-bit result into W. The file register is left unchanged.

The bits obtained from the register are shifted right by one bit position. C is shifted into the most significant bit position and the least significant bit is shifted out into C, as shown in the diagram below.

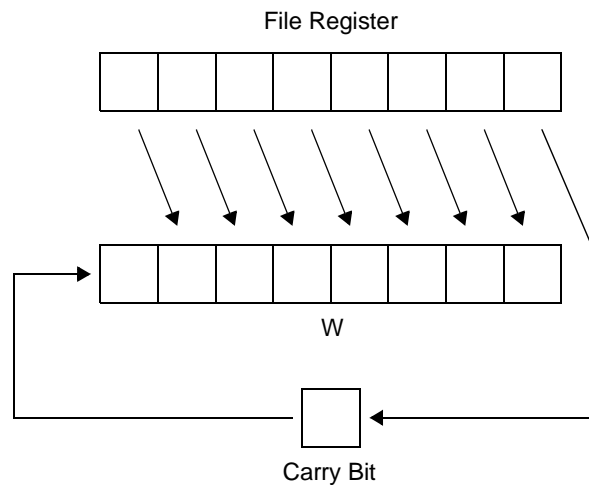

Figure 3-3 Rotate fr Right Through Carry into W

Cycles: 1

Example 1: `mov W,>>$0F`

This example rotates the bits of file register 0Fh right through the C bit and moves the result into W. If the file register contains 12h and the C bit is set to 1, after this instruction is executed, W will contain 89h and the C bit will be cleared to 0. The file register will still contain 12h after execution of the instruction.

3.6.30 MOV W,<>fr**Swap High/Low Nibbles of fr and Move to W**

Operation: W = <> fr

Bits affected: none

Opcode: 0011 100f ffff

Description: This instruction exchanges the high-order and low-order nibbles (4-bit segments) of the value in the specified file register and moves the result to W. The file register is left unchanged.

Cycles: 1

Example: mov W,<>\$0B

This example swaps the high-order and low-order nibbles of the value in file register 0Bh and moves the result into W. For example, if the file register contains A5h, after executing this instruction, W will contain 5Ah.

3.6.31 MOV W,#lit**Move Literal to W**

Operation: W = lit

Bits affected: none

Opcode: 1100 kkkk kkkk

Description: This instruction loads an 8-bit literal value (a value specified within the instruction) into W.

Cycles: 1

Example: mov W,#\$75

This example loads the immediate value 75h into W.

3.6.32 MOV W,M**Move MODE Register to W**

Operation: W = MODE

Bits affected: none

Opcode: 0000 0100 0010

Description: This instruction moves the contents of the MODE register into W. The MODE register is left unchanged. The MODE register operates as a pointer to the device port registers for subsequent accesses to those registers using the “MOV !rx,W” instruction.

Cycles: 1

Example:

```
mov    W,M      ;get MODE register contents
mov    $10,W    ;save value to file register 10h
```

This example moves the contents of the MODE register into W, and then stores that value into file register 10h.

3.6.33 MOVSZ W, --fr**Move (fr-1) to W and Skip if Zero**

Operation: W = fr - 1; if 0, then skip next instruction

Bits affected: none

Opcode: 0010 110f ffff

Description: This instruction decrements the value in the specified file register and moves the result to W. The file register is left unchanged.

If the result is zero, the next instruction in the program is skipped. Otherwise, program execution proceeds normally with the next instruction.

Cycles: 1 if tested condition is false; 2 if tested condition is true

Example:

```
movsz  W,--$1F    ;move register 1Fh -1 into W
ret          ;return from subroutine if 0
nop         ;execution continues here otherwise
```

This example takes the contents of file register 1Fh, decrements that value, and moves the result to W. If the result is zero, the device skips the “ret” instruction and proceeds with the “nop” instruction. If the result is nonzero, the device executes the “ret” instruction.

3.6.34 MOVSZ W, ++fr**Move (fr+1) to W and Skip if Zero**

Operation: $W = fr + 1$; if 0, then skip next instruction

Bits affected: none

Opcode: 0011 110f ffff

Description: This instruction increments the value in the specified file register and moves the result to W. The file register is left unchanged.

If the result is zero, the next instruction in the program is skipped. Otherwise, program execution proceeds normally with the next instruction.

Cycles: 1 if tested condition is false; 2 if tested condition is true

Example:

```
movsz  W,++$1F    ;move register 1Fh +1 into W
ret                                ;return from subroutine if 0
nop                                ;execution continues here otherwise
```

This example takes the contents of file register 1Fh, increments that value, and moves the result to W. If the result is zero, the device skips the “ret” instruction and proceeds with the “nop” instruction. If the result is nonzero, the device executes the “ret” instruction.

3.6.35 NOP**No Operation**

Operation: none

Bits affected: none

Opcode: 0000 0000 0000

Description: This instruction does nothing except to cause a one-cycle delay in program execution.

Cycles: 1

Example: sb \$05.4 ;set bit 4 in Port A
nop ;no operation, 1-cycle delay
sb \$05.6 ;set bit 5 in Port A

This example shows how a “nop” instruction can be used as a one-cycle delay between two successive read-modify-write instructions that modify the same I/O port. This delay ensures reliable results at high clock rates.

3.6.36 NOT fr**Complement of fr into fr**

Operation: $fr = fr \wedge FFh$

Bits affected: Z

Opcode: 0010 011f ffff

Description: This instruction complements each bit of the specified file register and writes the result back into the same register. If the result is 00h, the Z bit is set.

Cycles: 1

Example: `not $11 ;complement file register 11h`

Suppose that W contains the value 1Ch. This instruction takes the complement of 1Ch and writes the result, E3h, into the same register. The result is nonzero, so the Z bit is cleared.

3.6.37 OR fr,W**OR of fr and W into fr**

Operation: $fr = fr | W$

Bits affected: Z

Opcode: 0001 001f ffff

Description: This instruction performs a bitwise logical OR of the contents of the specified file register and W, and writes the 8-bit result into the same file register. W is left unchanged. If the result is 00h, the Z bit is set.

Cycles: 1

Example: `or $10,W ;perform logical OR and overwrite fr`

This example performs a bitwise logical OR of the working register W with a value stored in file register 10h. The result is written back to the file register 10h.

For example, suppose that the file register 10h is loaded with the value 0Fh and W contains the value 13h. The instruction takes the logical OR of 0Fh and 13h and writes the result, 1Fh, into the same file register. The result is nonzero, so the Z bit is cleared.

3.6.38 OR W,fr**OR of W and fr into W**

Operation: $W = W \mid fr$

Bits affected: Z

Opcode: 0001 000f ffff

Description: This instruction performs a bitwise logical OR of the contents of W and the specified file register, and writes the 8-bit result into W. The file register is left unchanged. If the result is 00h, the Z bit is set.

Cycles: 1

Example: `or W,$0B ;perform logical OR and overwrite W`

This example performs a bitwise logical OR of the value stored in file register 0Bh with W. The result is written back to W.

For example, suppose that the file register 0Bh is loaded with the value 0Fh and W contains the value 13h. The instruction takes the logical OR of 0Fh and 13h and writes the result, 1Fh, into W. The result is nonzero, so the Z bit is cleared.

3.6.39 OR W,#lit**OR of W and Literal into W**

Operation: $W = W \mid \text{lit}$

Bits affected: Z

Opcode: 1101 kkkk kkkk

Description: This instruction performs a bitwise logical OR of the contents of W and an 8-bit literal value, and writes the 8-bit result into W. If the result is 00h, the Z bit is set.

Cycles: 1

Example: `or W,#$0F ;set four low-order bits of W`

This example performs a bitwise logical OR of W with the literal value #0Fh. The result is written back to W.

For example, suppose that W contains the value 50h. The instruction takes the logical OR of this value with 0Fh and writes the result, 5Fh, into W. The result is nonzero, so the Z bit is cleared.

3.6.40 PAGE addr12**Load Page Number into STATUS(7:5)**

Operation: STATUS(7:5) = addr12(11:9)

Bits affected: none

Opcode: 0000 0001 0nnn

Description: This instruction writes a three-bit value into the PA2:PA0 bits of the STATUS register (bits 7:5). These bits select the program memory page for subsequent “jump” and “call” instructions.

In the syntax of the assembly language, you specify the page using a full 12-bit program memory address. The assembler encodes the three high-order bits of this address into the instruction opcode and ignores the nine low-order bits. The three high-order bits are written into the PA2:PA0 field of the STATUS register.

If a skip instruction is immediately followed by PAGE instruction (and tested condition is true) then two instructions are skipped and the operation consumes three cycles. This is useful for conditional branching to another page where a PAGE instruction precedes a JMP. If several PAGE instructions immediately follow a skip instruction then they are skipped plus the next instruction and a cycle is consumed for each.

Cycles: 1

Example: `page $400 ;set page bits PA2:PA0 to 010 binary`
`jump home1 ;jump to address in page 2`

This example sets the PA2:PA0 bits in the STATUS register to 010. This means that the subsequent “call” instruction calls a subroutine that starts in page 2 of program memory (somewhere in the address range of 400h to 5FFh).

3.6.41 RET

Return from Subroutine

Operation: program counter = top-of-stack

Bits affected: none

Opcode: 0000 0000 1100

Description: This instruction causes a return from a subroutine. It pops the 12-bit value previously stored on the stack and restores that value to the program counter. This causes the program to jump to the instruction immediately following the “call” instruction that called the subroutine.

It is not necessary to set the PA2:PA0 bits in the STATUS register in order to return to the correct place in the program. This is because the full 12-bit program address is restored from the stack. The “ret” instruction does not use (and does not affect) the PA2:PA0 bits. It also does not affect the W register.

If you want to automatically configure the PA2:PA0 bits to select the current page (the page of the instruction following the call instruction), use RETP instead of RET.

Cycles: 2 in “compatible” mode, or 3 in “turbo” mode

```

Example:   page   $000           ;set page of subroutine in STATUS reg.
          call   addxy          ;call subroutine addxy
          mov    $0C,W          ;use addxy subroutine results
          ...                    ;more of program (not shown)
          addxy                    ;subroutine address label
          mov    W,$0E          ;subroutine instructions start here
          add    W,$0F
          ...
          ret                    ;return from subroutine
  
```

The “call” instruction in this example calls a subroutine called “addxy.” When the “call” instruction is executed, the address of the following instruction (the “mov \$0C,W” instruction) is pushed onto the stack and the program jumps to the “addxy” routine. When the “ret” instruction is executed, the saved program address is popped from the stack and restored to the program counter, which causes the program to continue with the instruction immediately following the “call” instruction.

3.6.42 RETI**Return from Interrupt**

Operation: restore W, STATUS, FSR, and program counter from shadow registers

Bits affected: STATUS register restored, which affects all bits

Opcode: 0000 0000 1110

Description: This instruction causes a return from an interrupt service routine. It restores the 12-bit program counter value that was saved when the interrupt occurred. This causes the program to return to the point in the program where the interrupt occurred. The instruction also restores the contents of W, STATUS, and FSR registers that were saved when the interrupt occurred.

Cycles: 2 in “compatible” mode, or 3 in “turbo” mode

```
Example:  org      0           ;interrupt routine at address 000h
          mov     M,#$09      ;set up MODE register to access WKPND_B
          clr     W           ;clear W
          mov     !RB,W       ;exchange W and WKPND_B contents
          and     W,#$0F      ;mask out unused bits of WKPND_B
          mov     $1A,W       ;move pending bits to register 1Ah
          ...                ;test pending bits perform service
          reti              ;return from interrupt
```

This is an example of an interrupt service routine that services interrupts triggered on the RB0, RB1, RB2, and RB3 pins. When an interrupt occurs, the device saves the 12-bit contents of the program counter and the contents of the W, STATUS, and FSR registers into a set of shadow registers. The program then jumps to the interrupt service routine, which starts at address 000h. The interrupt service routine determines the cause of the interrupt, clears the applicable interrupt pending bit, performs the required task, and ends with the “reti” instruction.

The “reti” instruction restores the contents of the program counter and the W, STATUS, and FSR registers. This causes the device to continue program execution at the point where the program was interrupted.

3.6.43 RETIW**Return from Interrupt and Adjust RTCC with W**

Operation: $RTCC = RTCC + W$

restore W, STATUS, FSR, and program counter from shadow registers

Bits affected: STATUS register restored, which affects all bits

Opcode: 0000 0000 1111

Description: Like the RETI instruction, the RETIW instruction causes a return from an interrupt service routine. It restores the 12-bit program counter value that was saved when the interrupt occurred. This causes the program to return to the point in the program where the interrupt occurred.

Before it returns from the interrupt service routine, the RETIW instruction first adds W to the Real-Time Clock Counter (RTCC). Then it restores the contents of the W, STATUS, and FSR registers and the program counter that were saved when the interrupt occurred.

Adding W to RTCC allows the interrupt service routine to restore the RTCC to the value it contained at the time the main program was interrupted. To use this feature, the interrupt service routine should check the RTCC at the beginning of the routine and again at the end of the routine, and then put the adjustment value into W before returning from the interrupt.

Cycles: 2 in “compatible” mode, or 3 in “turbo” mode

Example:

```
...      ;interrupt service routine at address 000h
...      ;check RTCC
...      ;check interrupt pending bits
...      ;perform interrupt service
...
...      ;check RTCC
...      ;put adjustment value into W
retiw    ;return from interrupt and adjust RTCC
```

3.6.44 RETP**Return from Subroutine Across Page Boundary**

Operation: STATUS(PA2:PA0) = top-of-stack (11:9)
program counter = top-of-stack

Bits affected: none

Opcode: 0000 0000 1101

Description: Like the RET instruction, the RETP instruction causes a return from a subroutine. It pops the 12-bit value previously stored on the stack and restores that value to the program counter. This causes the program to jump to the instruction immediately following the “call” instruction that called the subroutine.

Unlike the RET instruction, the RETP instruction also writes bit 11:9 of the return address (the address of the instruction immediately following the “call” instruction) into the PA2:PA0 bits of the STATUS register. This automatically configures the PA2:PA0 bits to select the current page, allowing a subsequent same-page jump or call to be executed without using another “page” instruction.

Cycles: 2 in “compatible” mode, or 3 in “turbo” mode

```
Example:  org    $050      ;start of program in page 0
          ...
          page  $200      ;set PA2:PA0 bits to 001 (different page)
          call  subxy     ;call subroutine in different page
          ...
          call  addxy     ;call subroutine in same page
          ...
          addxy          ;subroutine in same page as call
          ...
          ret
          ...
          org    $200      ;new memory segment at 200h
          subxy          ;subroutine address label at 200h
          ...
          retp           ;return from subroutine (different page)
```

The first call crosses a 512-word page boundary (PA2:PA0 = 001). Upon return from that subroutine, the PA2:PA0 bits are automatically returned to their original values (PA2:PA0 = 00), allowing a subsequent same-page call to be done without using the “page” instruction again.

3.6.45 RETW lit

Return from Subroutine with Literal in W

Operation: W = lit

program counter = top-of-stack

Bits affected: none

Opcode: 1000 kkkk kkkk

Description: This instruction causes a return from a subroutine and also puts an 8-bit literal value into W. It pops the 12-bit value previously stored on the stack and loads that value into the program counter. This causes the program to jump to the instruction immediately following the “call” instruction that called the subroutine.

You can use multiple “RETW lit” instructions to implement a data lookup table.

Cycles: 2 in “compatible” mode, or 3 in “turbo” mode

Example:

```

mov W,$0A ;load W with value to be squared (0-7)
call square ;call lookup-table subroutine
mov $0B,W ;use subroutine results (in W)
... ;more of program (not shown)
square ;subroutine entry point
and W,#$07 ;ensure that W is less than 8
add $02,W ;add W to PC to jump to applicable retw
retw 0 ;0 squared = 0, beginning of data table
retw 1 ;1 squared = 1
retw 4 ;2 squared = 4
retw 9 ;3 squared = 9
retw 16 ;4 squared = 16
retw 25 ;5 squared = 25
retw 36 ;6 squared = 36
retw 49 ;7 squared = 49, end of data table
  
```

The “square” subroutine calculates the square of W and returns the result in W. To use the subroutine, the program first loads W with the value to be squared, which must be a value from 0 to 7. The subroutine adds the contents of W to the program counter (the PC register at address 02h), which advances the program to the applicable “RETW lit” instruction. The “RETW lit” instruction returns from the subroutine with the appropriate result in W.

3.6.46 RL fr**Rotate fr Left through Carry**Operation: $fr = \ll fr$

Bits affected: C

Opcode: 0011 011f ffff

Description: This instruction rotates the bits of the specified file register left using the C bit bit. The bits inside the register are shifted left by one bit position. C is shifted into the least significant bit position and the most significant bit is shifted out into C, as shown in the diagram below.

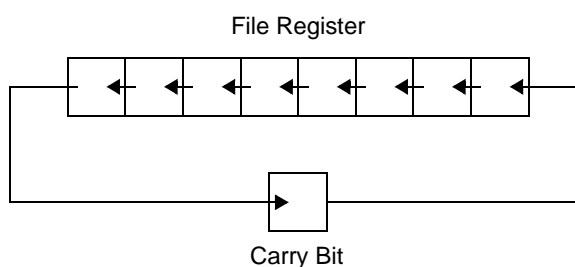
**Figure 3-4** Rotate fr Left Through Carry

Cycles: 1

Example 1: rl \$18

This example rotates the bits of file register 18h. If the register initially contains 14h and the C bit is set to 1, after executing this instruction, the register will contain 29h and the C bit will be cleared to 0.

```
Example 2:  clrb    $03.0    ;clear carry bit
            rl     $18      ;rotate left, reg=reg*2
            rl     $18      ;rotate left, reg=reg*2
```

This example multiplies file register 18h by 4. The initial “clrb” instruction clears the C bit, which ensures that 0 will be shifted into the least significant bit position. The two “rl” instructions perform two successive multiply-by-2 operations.

3.6.47 RR fr

Rotate fr Right through Carry

Operation: fr = >> fr

Bits affected: C

Opcode: 0011 001f ffff

Description: This instruction rotates the bits of the specified file register right using the C bit bit. The bits inside the register are shifted right by one bit position. C is shifted into the most significant bit position and the least significant bit is shifted out into C, as shown in the diagram below.

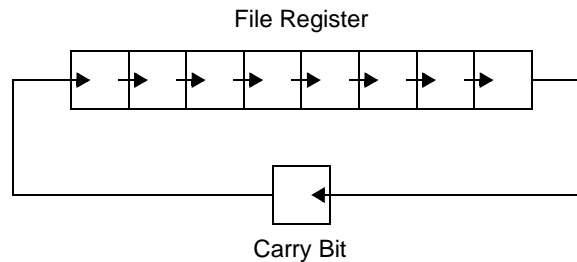

Figure 3-5 Rotate fr Right Through Carry

Cycles: 1

Example 1: rr \$0F

This example rotates the bits of file register 0Fh. If the register initially contains 12h and the C bit is set to 1, after executing this instruction, the register will contain 89h and the C bit will be cleared to 0.

```
Example 2:  clrb    $03.0    ;clear carry bit
            rr      $0F     ;rotate right, reg=reg/2
            clrb    $03.0    ;clear carry bit
            rr      $0F     ;rotate right, reg=reg/2
```

This example divides file register 0Fh by 4. The “clrb” instructions ensure that 0 will be shifted into the most significant bit positions. The two “rr” instructions perform two divide-by-2 operations.

3.6.48 SB fr.bit**Test Bit in fr and Skip if Set**

Operation: Test a specified bit in fr; if 1, skip next instruction

Bits affected: none

Opcode: 0111 bbbf ffff

Description: This instruction tests a bit in the specified file register. The file register address (00h through 1Fh) and the bit number (0 through 7) are the instruction operands. If the bit is 1, the next instruction in the program is skipped. Otherwise, program execution proceeds normally with the next instruction.

Cycles: 1 if tested condition is false, 2 if tested condition is true

Example:

```
sb    $1F.7    ;test bit 7 of file register
inc   $1F      ;increment if bit=0
mov   W,$1F    ;move file register to W
```

This example tests the most significant bit of file register 1Fh. If that bit is 1, the “inc” instruction is skipped. Otherwise, program execution proceeds normally with the “inc” instruction.

3.6.49 SETB fr.bit**Set Bit in fr**

Operation: Set a specified bit in fr

Bits affected: none

Opcode: 0101 bbbf ffff

Description: This instruction sets a bit in the specified file register to 1 without changing the other bits in the register. The file register address (00h through 1Fh) and the bit number (0 through 7) are the instruction operands.

Cycles: 1

Example: `setb $1F,7`

This example sets the most significant bit of file register 1Fh.

3.6.50 SLEEP**Power Down Mode**

Operation: WDT = 00h
STATUS(TO) = 1, STATUS(PD) = 0

stop oscillator

Bits affected: none

Opcode: 0000 0000 0011

Description: This instruction places the device in the power down mode. If the Watchdog timer is enabled, the WDT register is cleared, the TO (timeout) bit in the STATUS register is set to 1, and the PD (power down) bit in the STATUS register is cleared to 0.

There are three types of events that can cause an exit from the power down mode: a Watchdog timer overflow, a transition on a Multi-Input Wakeup pin, or an external reset on the $\overline{\text{MCLR}}$ pin. For more information on the power down mode, see [Section 4.3](#).

Cycles: 1

Example: sleep

This example puts the device into the power down mode until a wakeup event occurs.

3.6.51 SNB fr.bit**Test Bit in fr and Skip if Clear**

Operation: Test a specified bit in fr; if 0, skip next instruction

Bits affected: none

Opcode: 0110 bbbf ffff

Description: This instruction tests a bit in the specified file register. The file register address (00h through 1Fh) and the bit number (0 through 7) are the instruction operands. If the bit is 0, the next instruction in the program is skipped. Otherwise, program execution proceeds normally with the next instruction.

Cycles: 1 if tested condition is false, 2 if tested condition is true

Example:

```
snb    $1F,5    ;test bit 5 of file register
dec    $1F      ;decrement if bit=1
mov    W,$1F    ;move file register to W
```

This example tests bit number 5 of file register 1Fh. If that bit is 0, the “dec” instruction is skipped. Otherwise, program execution proceeds normally with the “dec” instruction.

3.6.52 SUB fr,W**Subtract W from fr**Operation: $fr = fr - W$

Bits affected: C, DC, Z

Opcode: 0000 101f ffff

Description: This instruction subtracts the contents of W from the contents of the specified file register and writes the 8-bit result into the same file register. W is left unchanged. The register contents are treated as unsigned values.

If the result of subtraction is negative (W is larger than fr), the C bit is cleared to 0 and the lower eight bits of the result are written to the file register. Otherwise, the C bit is set to 1.

If there is a borrow from bit 3 to bit 4, the DC (digit carry) bit is cleared to 0. Otherwise, the bit is set to 1.

If the result of subtraction is 00h, the Z bit is set. Otherwise, the bit is cleared.

Config. Option: If the \overline{CF} bit in the FUSEX configuration register has been programmed to 0, this instruction also subtracts the complement of the C bit as a borrow-in input:

$$fr = fr - W - \overline{C}$$

See Example 2 below for a program example of multiple-byte subtraction with borrow.

Cycles: 1

Example 1: sub \$0D,W

This example subtracts the contents of W from file register 0Dh. For example, if the file register contains 35h and W contains 06h, this instruction subtracts 06h from 35h and writes the result, 2Fh, into the file register. It also sets the C bit, clears the DC bit, and clears the Z bit.

Example 2:

```
set $03.0 ;set carry bit for no borrow in
mov W,$0A ;load W from 0Ah (low-order byte)
sub $0C,W ;low-order subtraction, C=0 for borrow out
mov W,$0B ;load W from 0Bh (high-order byte)
sub $0D,W ;high-order subtraction, borrow in & out
```

This example performs 16-bit subtraction of file registers 0Ah-0Bh from file registers 0Ch-0Dh. For this example, the \overline{CF} bit in the FUSEX configuration register is programmed to 0 in order to implement subtraction with borrow.

The first “sub” instruction subtracts the contents of 0Ah from 0Ch and clears the C bit if a borrow occurs out of bit 7, or sets the C bit otherwise. The second “sub” instruction subtracts the contents of 0Bh from 0Dh with borrow-in using the C bit.

This algorithm can also be implemented with the device in the default configuration (with the \overline{CF} bit set to 1 in the FUSEX register), although not as efficiently. For example, you can do the low-order subtraction, test the carry bit, decrement file register 0Dh if the carry bit is 0, and then do the high-order subtraction.

3.6.53 SWAP**Swap High/Low Nibbles of fr**

Operation: fr = $\langle \rangle$ fr

Bits affected: none

Opcode: 0011 101f ffff

Description: This instruction exchanges the high-order and low-order nibbles (4-bit segments) of the specified file register.

Cycles: 1

Example: swap \$0B

This example swaps the high-order and low-order nibbles of file register 0Bh. For example, if the register contains A5h, after executing this instruction, the register will contain 5Ah.

3.6.54 TEST fr**Test fr for Zero**

Operation: fr = fr

Bits affected: Z

Opcode: 0010 001f ffff

Description: This instruction moves the contents of the specified file register into the same register. There is no net effect except to set or clear the Z bit. If the register contains 00h, the bit is set. Otherwise, the bit is cleared.

Cycles: 1

Example:

```
test    $1B        ;test file register 1Bh
sb      STATUS.2  ;test Z bit and skip if set
inc     $1B        ;increment file reg 1Bh if nonzero
mov     W,$1B     ;move file reg 1Bh to W
```

This example tests the contents of file register 1Bh. The “test” instruction sets or clears the Z bit based on the contents of the file register. The “sb” instruction tests the Z bit. The “inc” instruction is executed if the file register contains zero or is skipped if the file register contains a nonzero value.

3.6.55 XOR fr,W**XOR of fr and W into fr**

Operation: $fr = fr \wedge W$

Bits affected: Z

Opcode: 0001 101f ffff

Description: This instruction performs a bitwise exclusive OR of the contents of the specified file register and W, and writes the 8-bit result into the same file register. W is left unchanged. If the result is 00h, the Z bit is set.

Cycles: 1

Example: `xor $10,W ;perform logical XOR and overwrite fr`

This example performs a bitwise logical XOR of the working register W with a value stored in file register 10h. The result is written back to the file register 10h.

For example, suppose that the file register 10h is loaded with the value 0Fh and W contains the value 13h. The instruction takes the logical XOR of 0Fh and 13h and writes the result, 1Ch, into the same file register. The result is nonzero, so the Z bit is cleared.

3.6.56 XOR W,fr**XOR of W and fr into W**

Operation: $W = W \wedge fr$

Bits affected: Z

Opcode: 0001 100f ffff

Description: This instruction performs a bitwise exclusive OR of the contents of W and the specified file register, and writes the 8-bit result into W. The file register is left unchanged. If the result is 00h, the Z bit is set.

Cycles: 1

Example: `xor W,$0B ;perform logical XOR and overwrite W`

This example performs a bitwise logical XOR of the value stored in file register 0Bh with W. The result is written back to W.

For example, suppose that the file register 0Bh is loaded with the value 0Fh and W contains the value 13h. The instruction takes the logical XOR of 0Fh and 13h and writes the result, 1Ch, into W. The result is nonzero, so the Z bit is cleared.

3.6.57 XOR W,#lit**XOR of W and Literal into W**

Operation: $W = W \wedge \text{lit}$

Bits affected: Z

Opcode: 1111 kkkk kkkk

Description: This instruction performs a bitwise exclusive OR of the contents of W and an 8-bit literal value, and writes the 8-bit result into W. If the result is 00h, the Z bit is set.

Cycles: 1

Example: `xor W,$#0F ;complement four low-order bits of W`

This example performs a bitwise logical XOR of W with the literal value #0Fh. The result is written back to W.

For example, suppose that W contains the value 51h. The instruction takes the logical XOR of this value with 0Fh and writes the result, 5Eh, into W. The result is nonzero, so the Z bit is cleared.



Chapter 4

Clocking, Power Down, and Reset

4.1 Introduction

The SX device can be configured to operate in any one of several clocking modes. You can use the built-in oscillator, an external oscillator circuit, or an external clock signal to drive the device. Each type of clock has its advantages and disadvantages with respect to clock rate choices, rate accuracy, and cost.

The SX device supports a “power down” mode, which reduces power consumption to a very low level during periods of inactivity. This mode is invoked by executing the “SLEEP” instruction. During power down, the device is completely inactive (except for the Watchdog timer, if enabled). Upon “wake-up” from the power down mode, the device is reset.

A reset occurs for any of the following conditions: initial power-up, wake-up from the power down mode, brown-out, Watchdog timeout, or assertion of the $\overline{\text{MCLR}}$ input signal (Master Clear Reset). When a reset occurs, the program counter is initialized to the highest program address (7FFh or FFFh), where the application program should have a “jump” instruction to its initialization routine.

4.2 Clocking Options

You can configure the SX device to use an on-chip RC oscillator, an external RC oscillator, an external crystal/resonator, or an externally generated clock signal. This choice depends on the required speed and precision of the clock, as well as cost considerations.

There are two device pins used for clocking, called OSC1 and OSC2. The functions of these pins depend on the device configuration and the chosen clocking mode.

You select the desired clocking mode by programming the FUSE word register, a 12-bit register mapped into the program memory. This register is accessible only when you are programming the instruction memory of the device, not a run time. For information on the specific bit fields in the register and the corresponding clocking modes, see [Section 2.8](#).

4.2.1 Clock/Instruction Rate Option (Compatible or Turbo Mode)

When you select the clock type, you need to consider the clock/instruction rate option. This option lets you select one of two instruction clocking modes, called the “compatible” mode and the “turbo” mode.

In the “compatible” mode, the instruction rate is one-fourth of the clock rate. In this configuration, you need to select a clock rate four times higher than the intended instruction rate. For example, if you want

to execute instructions at a rate of 1 MHz (one instruction per microsecond), you need to select a clock rate of 4 MHz. This mode is designed for compatibility with the PIC16C5x series of microcontroller devices.

In the “turbo” mode, the instruction rate is equal to the clock rate. For example, if you want to execute instructions at a rate of 50 MHz (one instruction per 20 nanoseconds), you use a 50 MHz clock. This is the preferred operating mode for new designs because you can use a slower clock to achieve a given instruction rate, thus reducing electromagnetic interference (EMI) in the system and the cost of the oscillator.

4.2.2 Internal RC Oscillator

Using the on-chip, built-in RC (resistor-capacitor) oscillator for the device clock is the lowest-cost option because no external components are required. This mode is suitable for lower-speed applications (4 MHz or less) where high accuracy is not needed. For this mode, you leave the OSC1 and OSC2 pins unconnected.

The internal RC oscillator operates at a nominal rate of 4 MHz and has an accuracy of plus or minus 8% over the allowed temperature range. The device can be configured to divide this clock down to produce a lower-rate clock for device operation, with the divide-by factor selected by programming the DIV1:DIV0 bits (SX18/20/28AC) and the DIV2:DIV0 (SX48/52BD) in the FUSE word as follows:

4.2.3 External RC Oscillator

Using an external RC oscillator network is a low-cost option suitable for applications that do not require high precision. The only external components required are a resistor and a capacitor. Unlike the internal RC oscillator, you can choose any operating frequency for which the device is rated, not just certain frequencies between 31.25 kHz and 4 MHz.

The RC oscillator operating rate is a function of the resistor and capacitor values, the supply voltage, and the operating temperature. The operating rate will vary from unit to unit due to normal variations in component values, and from time to time due to fluctuations in temperature and voltage. Therefore, an application that requires high precision (for example, a system with a real-time clock) should use an external resonator or crystal rather than an RC oscillator.

Figure 4-1 shows how the resistor and capacitor are connected to the device. The operating frequency can be adjusted by choosing the values for R and C.

In this operating mode, OSC1 is the clock input and OSC2 operates as a clock output. The input signal is amplified and fed back to the pin through a transistor to stabilize the clock signal. The output clock signal is created by dividing the internal clock by 4. For example, if the RC clock operates at 8 MHz, the OSC2 output clock will operate at 2 MHz.

A resistor value between 3 k Ω and 100 k Ω is recommended. For resistor values below this range, the oscillator might become unstable or stop completely. For resistor values higher than this range, the oscillator becomes sensitive to noise, humidity, and capacitor leakage.

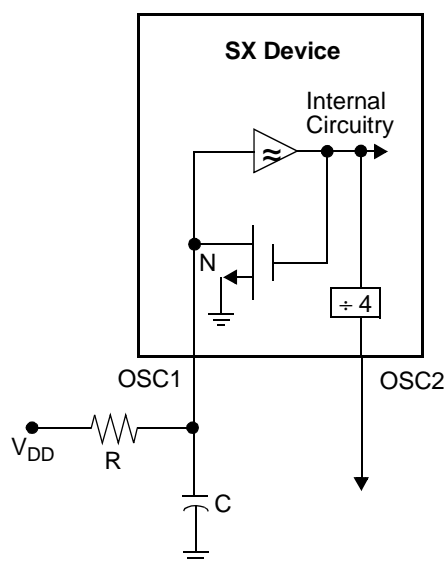

Figure 4-1 External RC Oscillator Connections

Although the device will operate without a capacitor ($C = 0$ pF), a capacitor of at least 20 pF is recommended for noise immunity and stability. For capacitance values lower than this, the oscillator frequency can vary significantly due to reliance on the small parasitic capacitance associated with the PCB traces and device package.

4.2.4 External Crystal/Resonator (XT, LP, or HS Mode)

Using an external crystal or ceramic resonator to generate the clock is suitable for a system that requires precise and accurate timing (for example, for a real-time clock). These types of oscillators cost more than RC oscillators.

The SX device can be configured to operate in any one of the following external crystal/resonator modes.

SX18/20/28AC:

- LP1– low-power crystal (32 KHz)
- LP2 – low-power crystal (32 KHz to 1 MHz)
- XT1 – normal crystal (32 KHz to 10 MHz)
- XT2 – normal crystal (1 MHz to 24 MHz)
- HS – high-speed crystal (1 MHz to 50 MHz)

SX48/52BD:

- LP– Low Power Crystal
- XT– Crystal/Resonator
- HS– High-Speed Crystal/Resonator

With the SX device configured in one of these modes, the crystal or ceramic resonator is connected to the OSC1 and OSC2 pins as shown in [Figure 4-2](#). The recommended external component values are specified in the device datasheet.

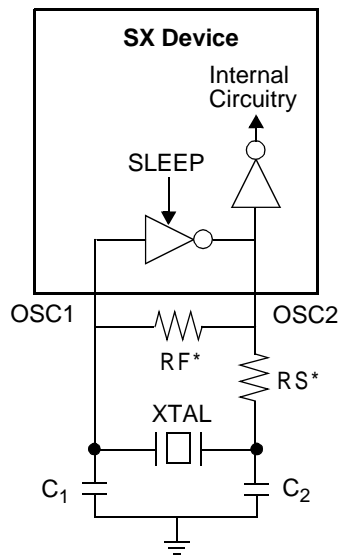

Figure 4-2 Crystal or Ceramic Resonator Connections

If you use a crystal, a parallel resonant type crystal is recommended. Using a series resonant type crystal may result in a frequency that is outside of the crystal manufacturer's recommended range.

4.2.5 External Clock Signal

You can use an externally generated clock signal to drive the SX device. This mode is suitable for systems in which there is already a clock signal available (used to drive other chips in the system) that can also be used to drive the SX device. The clock signal must meet the clock specifications of the SX device, including the duty cycle, rise time, fall time, and voltage levels.

To use this mode, configure the device to operate in the XT, LP, or HS mode. It does not matter which one of these modes you select. Then connect the clock signal to the OSC1 input and leave the OSC2 pin unconnected, as shown in [Figure 4-3](#).

4.3 Power Down Mode

In the SX power down mode, the device is shut down and the clock is stopped to all parts of the device. The Watchdog timer, if enabled, continues to operate because it uses its own independent on-chip oscillator. Upon wakeup from the power down mode, the device is reset and the program jumps to the highest program address (7FFh or FFFh, depending on the SX device type).

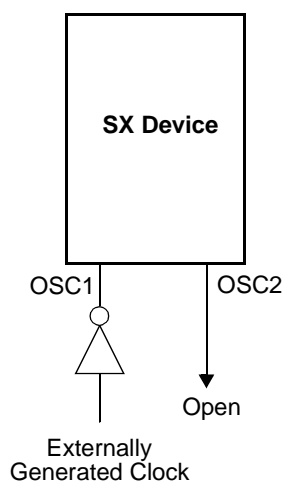

Figure 4-3 External Clock Signal Connection

4.3.1 Entering the Power Down Mode

For the lowest possible power consumption in the power down state, disable the Watchdog timer. This eliminates the power consumption of the Watchdog oscillator and counter. In that case, however, you will not be able to use a Watchdog timeout to wake up the device.

The device enters the power down mode upon execution of the “SLEEP” instruction. Program execution stops and the device is powered down until a wakeup event occurs.

If the Watchdog timer is enabled, the “SLEEP” instruction sets the TO (Watchdog Timeout) bit to 1 and clears the PD (Power Down) bit to 0 in the STATUS register. The Watchdog timer continues to operate while the device is powered down. A Watchdog timeout will then wake up the device from the power down state.

4.3.2 Waking Up from the Power Down Mode

Any one of the following events will cause a wakeup from the power down state:

- a timeout signal from the Watchdog timer, generated when the Watchdog timer overflows
- a valid transition on any Port B pin configured to operate as a Multi-Input Wakeup pin
- a low voltage on the $\overline{\text{MCLR}}$ input pin (Master Clear Reset)
- a brown-out reset resulting from a low voltage on the power supply

When a wakeup event occurs, the TO and PD bits are both set to 1 in the STATUS register, and program execution resumes at the highest program memory address, just like an ordinary reset operation. The highest program memory address should contain an instruction to jump to the device initialization routine.

4.4 Multi-Input Wakeup/Interrupt

The Multi-Input Wakeup circuit allows the Port B pins to be used as device inputs to wake up the device from the power down state, or to trigger an interrupt from an external source.

The same Multi-Input Wakeup circuit is used for both wakeups and interrupts. In the power down state, a wakeup signal on a Port B pin wakes up and resets the device, causing the program to jump to the highest program memory address (7FFh or FFFh, depending on the SX device type). The same signal received on a Port B pin during normal operation triggers an interrupt, which causes the device to save the program context (program counter, W, STATUS, and FSR) and then jump to the lowest memory address (000h). For more information on interrupts, see [Chapter 6](#).

4.4.1 Port B Configuration for Multi-Input Wakeup/Interrupt

Figure 4-4 is a block diagram of the Multi-Input Wakeup circuit. The circuit uses the I/O pins of Port B for the wakeup inputs. Port B must be properly configured for Multi-Input Wakeup operation. The eight Port B pins can be individually configured for this purpose. You control the port configuration by writing to its configuration registers using the “mov !RB,W” instruction. Selection of those registers is controlled by the MODE register.

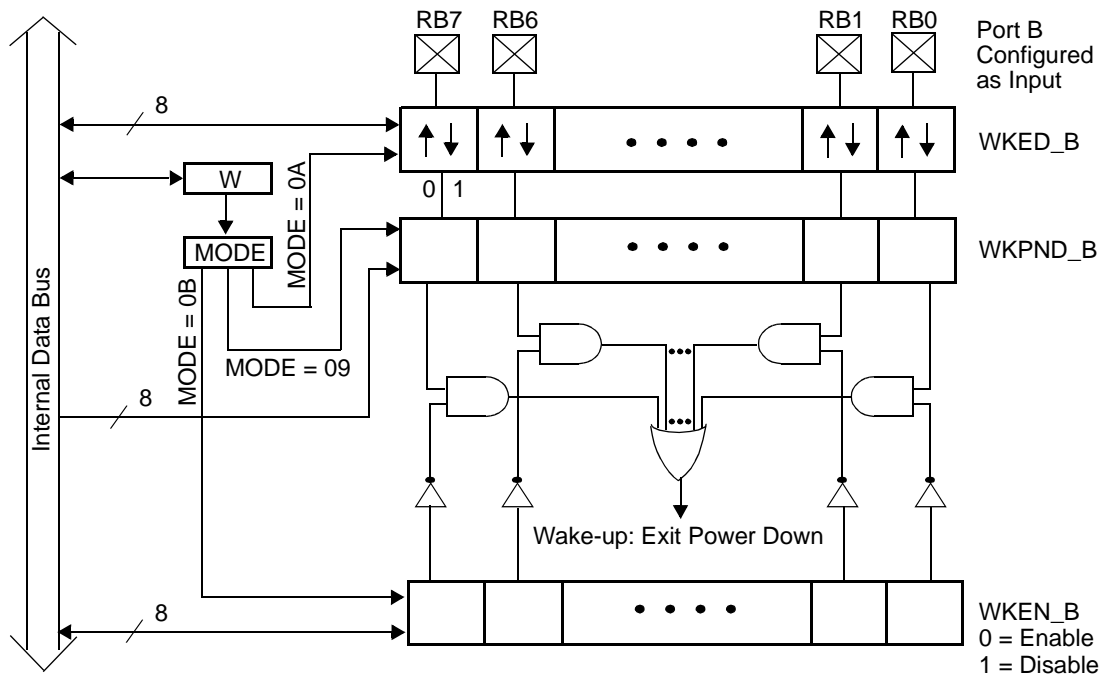

Figure 4-4 Multi-Input Wakeup/Interrupt Block Diagram

These are the configuration registers that you must program in order to prepare Port B pins for Multi-Input Wakeup/Interrupt operation:

- RB Data Direction register
- WKEN_B (Port B Wakeup Enable register)
- WKED_B (Port B Wakeup Edge Select register)

- WKPND_B (Port B Wakeup Pending Flag register)

To make a Port B pin operate as a high-impedance input (not as an output), set the corresponding bit to 1 in the RB data direction register.

To enable a Port B pin to operate as a Multi-Input Wakeup input, clear the corresponding bit to 0 in the WKEN_B register.

To specify the edge sensitivity of the pin, set or clear the corresponding bit in the WKED_B register. Set the bit to 1 to sense falling edges (high-to-low transitions) or clear the bit to 0 to sense rising edges (low-to-high transitions). An edge of the specified type on the wakeup-enabled pin will trigger a wakeup or interrupt.

The WKPND_B register contains flag bits that indicate occurrences of wakeup/interrupt events on the Port B pins. When a valid edge is received on a wakeup-enabled pin, it sets the corresponding flag bit is set to 1 in the WKPND_B register and triggers the wakeup or interrupt. The program can read the WKPND_B register to determine which Port B pin received the wakeup/interrupt signal.

Upon reset, the WKPND_B register contains unknown data. Therefore, the program should clear this register to zero before it enables the Multi-Input Wakeup function in the WKEN_B register. Otherwise, the program will not be able to determine which pin received the wakeup signal.

Upon reset, the WKEN_B register is set to FFh. This disables the wakeup interrupts by default. You must explicitly enable any pins that you want to use as wakeup/interrupt pins.

Here is an example of a program segment that configures the RB0, RB1, and RB2 pins to operate as Multi-Input Wakeup/Interrupt pins, sensitive to falling edges:

```

mov  M,#$0F      ;prepare to write port data direction registers
mov  W,#$07      ;load W with the value 07h
mov  !RB,W       ;configure RB0-RB2 to be inputs

mov  M,#$0A      ;prepare to write WKED_B (edge) register
                    ;W contains the value 07h
mov  !RB,W       ;configure RB0-RB2 to sense falling edges

mov  W,#$09      ;value of 09h to be written to MODE register
mov  M,W         ;prepare to access WKPND_B (pending) register
mov  W,#$00      ;clear W
mov  !RB,W       ;clear all wakeup pending flags

mov  M,#$0B      ;prepare to write WKEN_B (enable) register
mov  W,#$F8h     ;load W with the value F8h
mov  !RB,W       ;enable RB0-RB2 to operate as wakeup inputs
  
```

To prevent false interrupts, the enabling step (clearing bits in WKEN_B) should be done as the last step in a sequence of Port B configuration steps.

After this program segment is executed, the device can receive interrupts on the RB0, RB1, and RB2 pins. If the device is put into the power down mode (by executing a “SLEEP” instruction), the device can then receive wakeup signals on those same pins.

4.4.2 Reading and Writing the Wakeup Pending Bits

The interrupt service routine or initialization code can determine which pin received the wakeup signal by reading the WKPND_B register, as in the following example:

```

mov  M,#$09      ;set MODE register to access WKPND_B
mov  W,#$00      ;clear W
mov  !RB,W       ;exchange contents of W and WKPND_B
  
```

When the MODE register is set to provide access to WKPND_B or CMP_B, the instruction “mov !RB,W” performs an exchange between the contents of W and the port control register, rather than a simple move. In the example above, the “mov !RB,W” instruction simultaneously loads W with the current WKPND_B pending flags and clears the WKPND_B register. The program can test the bits in W to determine which Port B pin caused the wakeup or interrupt event. Clearing the WKPND_B register is necessary to enable detection of any subsequent wakeup or interrupt events on the Port B pins.

4.5 Reset

A reset operation puts the SX device into a known initial state. A reset occurs upon any one of the following conditions:

- initial power-up
- wakeup from the power down mode
- recovery from brown-out, as determined by the brown-out detection circuit
- Watchdog timeout
- assertion of the $\overline{\text{MCLR}}$ input signal (Master Clear Reset)

When a reset occurs, the program counter is initialized to the highest program address (7FFh or FFFh, depending on the SX device type), where the application program should have a “jump” instruction to its initialization routine.

Figure 4-5 shows the internal logic of the SX reset circuit. This circuit senses the voltage supply on the V_{DD} pin, the state of the $\overline{\text{MCLR}}$ (Master Clear Reset) input pin, the output of the on-chip RC oscillator, and signals from the Multi-Input Wakeup circuit and Watchdog timer. Based on these inputs, the circuit generates a chip-internal $\overline{\text{RESET}}$ signal. This signal goes low to put the device into the reset state and then goes high to allow the device to begin operating from a known state.

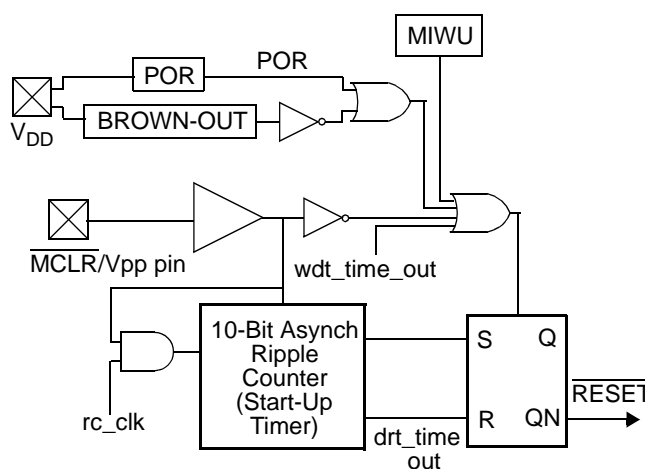

Figure 4-5 On-Chip Reset Circuit Block Diagram

4.5.1 Register States Upon Different Resets

The effect of different reset operations on a register depends on the register and the type of reset operation. Some registers are initialized to specific values, some are left unchanged (for wakeup and brown-out resets), and some are initialized to an unknown value. A register that starts with an unknown value should be initialized by the software to a known value; you cannot simply test the initial state and rely on it starting in that state consistently.

Table 4-1 lists the SX registers and shows the state of each register upon different resets. The column on the left lists the register names, and the first row shows the various types of reset operations. Each entry in the table shows the state of the register just after the applicable reset operation.

Table 4-1 Register States Upon Different Resets

Register	Power-On	Wakeup	Brown-out	Watchdog Timeout	MCLR
W	Undefined	Unchanged	Undefined	Unchanged	Unchanged
OPTION	FFh	FFh	FFh	FFh	FFh
MODE (SX18/20/28AC) MODE (SX48/52BD)	0Fh 1Fh	0Fh 1Fh	0Fh 1Fh	0Fh 1Fh	0Fh 1Fh
RTCC (01h)	Undefined	Unchanged	Undefined	Unchanged	Unchanged
PC (02h)	FFh	FFh	FFh	FFh	FFh
STATUS (03h)	Bits 0-2: Undefined Bits 3-4: 11 Bits 5-7: 000	Bits 0-2: Undefined Bits 3-4: Unch. Bits 5-7: 000	Bits 0-4: Undefined Bits 5-7: 000	Bits 0-2: Unchanged Bits 3-4: (Note 1) Bits 5-7: 000	Bits 0-2: Unchnaged Bits 3-4: (Note 2) Bits 5-7: 000
FSR (04h)	Undefined	Bits 0-6: Undefined Bit 7: 1	Bits 0-6: Undefined Bit 7: 1	Bits 0-6: Unchanged Bit 7: 1	Bits 0-6: Unchnaged Bit 7: 1
RA through RE Direction	FFh	FFh	FFh	FFh	FFh
RA through RE Data	Undefined	Unchanged	Undefined	Unchanged	Unchanged
Other File Registers	Undefined	Unchanged	Undefined	Unchanged	Unchanged
CMP_B	Bits 0, 6-7: 1 Bits 1-5: Undefined	Bits 0, 6-7: 1 Bits 1-5: Undefined	Bits 0, 6-7: 1 Bits 1-5: Undefined	Bits 0, 6-7: 1 Bits 1-5: Undefined	Bits 0, 6-7: 1 Bits 1-5: Undefined
WKPND_B	Undefined	Unchanged	Undefined	Unchanged	Unchanged
WKED_B	FFh	FFh	FFh	FFh	FFh
WKEN_B	FFh	FFh	FFh	FFh	FFh
ST_B through ST_E	FFh	FFh	FFh	FFh	FFh
LVL_A through LVL_E	FFh	FFh	FFh	FFh	FFh
PLP_A through PLP_E	FFh	FFh	FFh	FFh	FFh
Watchdog Counter	Undefined	Unchanged	Undefined	Unchanged	Unchanged
NOTE:	1. Watchdog reset during power down mode: 00 (bits TO, PD); Watchdog reset during Active mode: 01 (bits TO, PD)				
NOTE:	2. External reset during power down mode: 10 (bits TO, PD); External reset during Active mode: Unchanged (bits TO, PD)				

4.5.2 Power-On Reset

In a typical power-on situation, the supply voltage takes a known (approximate) amount of time to rise from zero volts to the final operating voltage. The SX device has an on-chip power-on reset circuit that holds the device in the reset state until the supply voltage rises to a stable operating level, thus ensuring reliable operation upon power-up.

The power-on reset circuit uses an asynchronous ripple counter to hold the device in the reset state for a period of time as the supply voltage rises. This counter, called the Delay Reset Timer (DRT), provides the device start-up delay. It is used only for a power-on reset, not for a reset caused by another event such as a wakeup from the power down mode or a brown-out.

Upon power-up, the internal reset latch is set, which asserts the internal $\overline{\text{RESET}}$ signal and holds the device in the reset state. The DRT counts clock pulses generated by the on-chip RC oscillator. It starts counting when the RC oscillator starts working and a valid logic high signal is detected on the $\overline{\text{MCLR}}$ input pin. When the DRT reaches the end of its timeout period (typically 72 msec), it clears the internal reset latch, which releases the device from the reset state.

The $\overline{\text{MCLR}}$ (Master Clear Reset) input pin must be held low upon power-up of the device. If you do not need to use the $\overline{\text{MCLR}}$ pin as a hardware reset input, you can simply tie it together with the V_{DD} power supply pin. This will work reliably only if the power supply rise time is significantly less than the DRT delay of 72 msec.

Figure 4-6 shows the power-on reset timing in this situation. The supply voltage and $\overline{\text{MCLR}}$ pin voltages rise together, and the DRT counter allows the device to begin operating after a delay of about 72 msec.

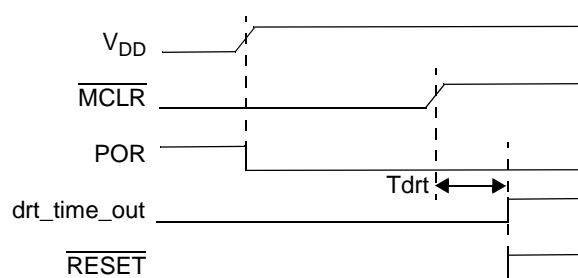

Figure 4-6 Power-On Reset Timing, Fast V_{DD} Rise Time

Figure 4-7 shows the unacceptable situation where the supply voltage rises too slowly, and the device is allowed to begin operating when the supply voltage has not yet reached a reliable level.

One solution to the situation shown in Figure 4-7 is to use an external RC delay circuit like the one shown in Figure 4-8. This circuit holds the $\overline{\text{MCLR}}$ input low while the supply voltage rises. The values of R and C should be chosen to cause a delay that exceeds the supply voltage rise time. R should be less than 40 k Ω to ensure a sufficiently high voltage. The diode helps to discharge the capacitor quickly when the power is turned off.

The power-on timing with the external RC network is shown in Figure 4-9. In this case, the device comes out of reset about 72 msec after the $\overline{\text{MCLR}}$ input goes high.

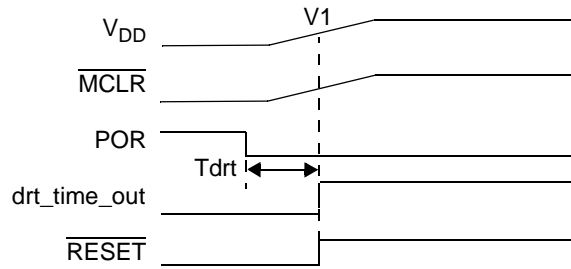

Figure 4-7 Power-On Reset Timing, V_{DD} Rise Time Too Slow

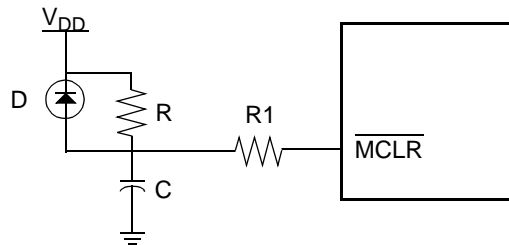

Figure 4-8 External Power-On $\overline{\text{MCLR}}$ Signal

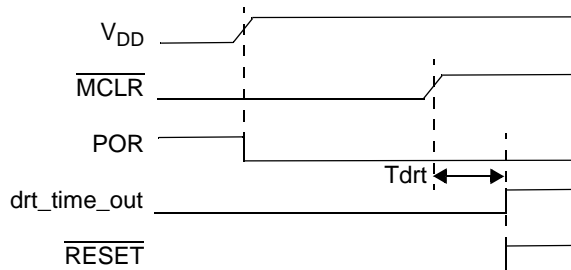

Figure 4-9 Power-On Reset Timing, Separate $\overline{\text{MCLR}}$ Signal

4.5.3 Wakeup from the Power Down Mode

A wakeup from the power down mode (described in [Section 4.3](#)) causes a device reset. The SX18/20/28AC devices have a fixed startup time of 18 ms when the wakeup reset occurs. The SX48/52BD devices have a programmable startup time. A 3-bit field in the FUSEX register can be used to specify the Delay Reset Timer (DRT) timeout period that results in an automatic wake-up from the power down mode:

- 101 = 0.06 msec
- 110 = 7.68 msec
- 111 = 18.4 msec (default)
- 000 = 60 msec
- 001 = 480 msec
- 010 = 960 msec
- 011 = 1920 msec

For fast start-up from the power down mode, clear the SLEEPCLK bit and set the WDRT2:WDRT0 field to 101. This will keep the clock operating during the power down mode and allow a 0.06 msec-start-up delay.

The device initialization routine can determine the Port B pin that caused the wakeup to occur by reading the WKPND_B register, as described in [Section 3.3.2](#).

4.5.4 Brown-Out Reset

When the supply voltage to the SX device drops below a specified value but remains above zero volts, it is called a “brown-out” condition. The SX device has a brown-out detection circuit that puts the device into the reset state when a brown-out occurs, and allows the device to re-start when the brown-out condition ends. This feature prevents the device from producing abnormal results when the supply voltage falls to unreliable levels.

The brown-out threshold voltage is factory-set to approximately 4.2 volts. If the supply voltage drops below this level but remains above zero, the brown-out circuit holds the SX device in the reset state. When the voltage rises above this threshold, the device starts operating again, starting at the reset address (the highest memory address).

You can optionally disable the brown-out detection circuit by setting the BOR0 and BOR1 bits to 1 in the FUSEX word register (a register programmed along with the instruction memory). In that case, the device will still operate below the brown-out threshold voltage, but will produce unreliable results if the supply voltage falls too low.

4.5.5 Watchdog Timeout

A Watchdog timeout occurs if the Watchdog circuit is enabled and the Watchdog timer overflows. This feature provides an escape mechanism from an infinite loop or other abnormal program condition. When a Watchdog timeout occurs, it resets the device just like assertion of the $\overline{\text{MCLR}}$ input.

4.5.6 $\overline{\text{MCLR}}$ Input Signal (Master Clear Reset)

A reset occurs whenever the $\overline{\text{MCLR}}$ (Master Clear Reset) input pin goes low. The device is held in the reset state as long as the $\overline{\text{MCLR}}$ pin is held low. When the input goes high, the program jumps to the reset address (the highest memory address). If you do not intend to use the $\overline{\text{MCLR}}$ pin as a hardware reset input, you should connect it together with the power supply pin (Vdd) or to a power-on RC network, as described in [Section 4.5.2](#).



Chapter 5

Input/Output Ports

5.1 Introduction

The SX device has a set of Input/Output (I/O) ports. Each port consists of a set of pins on which the device can read logic signals from other devices, or send logic signals to other devices. Each port pin can be individually software-configured to operate as an input or as an output, to accept TTL or CMOS voltage levels, and to use or not use an internal pullup resistor. Some ports allow the selection of Schmitt-trigger input characteristics.

All SX devices have at least a Port A and a Port B, with at least four pins in Port A and eight pins in Port B. Some devices also have a Port C, Port D, and/or Port E, with eight pins per port. The ports share many of the same features, but have some characteristics that vary from port to port:

- Port A offers symmetrical drive capability, which means that the same voltage drop occurs across the external load whether the output pin is sourcing or sinking current. There are either four or eight pins in this port, depending on the SX device type.
- The Port B pins can be software-configured to operate as general-purpose I/O pins, interrupt/wakeup inputs, or comparator I/O signals. There are eight pins in this port.
- The Port C, Port D, and Port E pins are general-purpose I/O pins available in certain devices. When available, there are eight pins per port. Some of these pins can be software-configured to operate as special-purpose I/O pins.

5.2 Reading and Writing the Ports

The I/O ports are memory-mapped into the data memory address space. To the CPU, the ports are available as the RA through RE file registers at data memory addresses 05h through 09h, respectively. Writing to a port data register sets the voltage levels of the corresponding port pins that have been configured to operate as outputs. Reading from a register reads the voltage levels of the corresponding port pins that have been configured as inputs.

For example, in a device that has four Port A pins, suppose that you want to use all four pins as outputs, and you want RA0 and RA1 to be high, and RA2 and RA3 to be low. You would first configure all four pins to operate as outputs, and then you would execute code such as the following:

```
mov  W,#$03      ;load W with the value 03h (bits 0 and 1 high)
mov  $05,W       ;write 03h to Port A data register
```

The second “mov” instruction in this example writes the Port A data register (RA), which controls the output levels of the four Port A pins, RA0 through RA3. Because Port A has only four I/O pins in this example, only the four least significant bits of this register are used. The four high-order register bits are “don’t care” bits.

To use all four Port A pins as inputs, you would first configure them to operate as inputs and then read them using code such as the following:

```
mov W,$05 ;move data from Port A into W
```

Note that pins can be individually configured within a port. For example, you could use some pins of Port A as inputs and others as outputs. For information on configuring the port pins, see [Section 5.3](#).

When a write is performed to a bit position for a port that has been configured as an input, a write to the port data register is still performed, but it has no immediate effect on the pin. If later the pin is configured to operate as an output, it will reflect the value that has been written to the data register.

For the SX48/52BD, a control bit called PORTRD in the T2CNT2 register determines how the device reads data from its I/O ports. Clear this bit to 0 to have the device read data directly from the port I/O pins (the default operating mode). Set this bit to 1 to have the device read data from the port data registers. Under normal conditions, it should not matter which method you use to read the port data. However, if a port pin is configured as an output and an external circuit forces the pin to the wrong value, the value read from the port will depend on the reading mode used.

The SX18/20/28AC always reads data directly from the port I/O pin, like the default operating mode of the SX48/52BD.

When you read from a bit position for a port in the default operating mode, you are actually reading the voltage level on the pin itself, not necessarily the bit value stored in the port data register. This is true whether the pin is configured to operate as an input or an output. Therefore, with the pin configured to operate as an input, the data register contents have no effect on the value that you read. With the pin configured to operate as an output, what you read generally matches what has been written to the register.

When you use two successive read-modify-write instruction on the same I/O port with a very high clock rate, the “write” part of one instruction might not occur soon enough before the “read” part of the very next instruction, resulting in getting “old” data for the second instruction. To ensure predictable results, avoid using two successive read-modify-write instructions that access the same port data register if the clock rate is high. For more information on this topic, see [Section 2.5.3](#).

5.3 Port Configuration

Each port pin offers the following configuration options:

- data direction
- input voltage levels (TTL or CMOS)
- pullup type (enable or disable)

- Schmitt trigger input (for ports other than Port A)
- Port read mode (for SX48/52BD only)

Port B offers the additional option to use the port pins for the Multi-Input Wakeup/Interrupt function and/or the analog comparator function. In some devices, other port pins can be similarly configured for special-purpose functions.

5.3.1 Accessing the Port Control Registers

You set the configuration of a port by writing to a set of control registers associated with the port. A special-purpose instruction is used to write or read these control registers:

- `mov !RA,W` (move data between W and Port A control register)
- `mov !RB,W` (move data between W and Port B control register)
- `mov !RC,W` (move data between W and Port C control register)
- `mov !RD,W` (move data between W and Port D control register)
- `mov !RE,W` (move data between W and Port E control register)

Each one of these instructions writes a port control register for Port A, Port B, Port C, Port D, or Port E. There are multiple control registers for each port. To specify which one you want to access, you use another register called the MODE register.

5.3.2 MODE Register

The MODE register controls access to the port configuration registers. Because the MODE register is not memory-mapped, it is accessed by the following special-purpose instructions:

- `mov M, #lit` (move 4-bit literal to MODE register)
- `mov M,W` (move W to MODE register)
- `mov W,M` (move MODE register to W)

The value contained in the MODE register determines which port control register is accessed by the “`mov !rx,W`” instruction, as indicated in [Table 5-1](#) for the SX18/20/28AC and in [Table 5-2](#) for the SX48/52BD. MODE register values not listed in the table are reserved for future expansion and should not be used. Upon reset, the MODE register is initialized to 0Fh for the SX18/20/28AC or to 1F for the SX48/52BD, which enables write access to the port direction registers.

After you write a value to the MODE register, that setting remains in effect until you change it by writing to the MODE register again. For example, you can write the value 1Eh to the MODE register just once, and then write to each of the pullup configuration registers using the instructions “`mov !RA,W`,” “`mov !RB,W`,” and so on.

Table 5-1 MODE Register Settings for SX18/20/28AC

MODE Reg.	Register Written by mov !RA,W	Register Written by mov !RB,W	Register Written by mov !RC,W
X8h		Exchange CMP_B	
X9h		Exchange WKPND_B	
XAh		WKED_B	
XBh		WKEN_B	
XCh		ST_B	ST_C
XDh	LVL_A	LVL_B	LVL_C
XEh	PLP_A	PLP_B	PLP_C
XFh	RA Direction	RB Direction	RC Direction

Table 5-2 MODE Register Settings for SX48/52BD

MODE Reg.	mov !RA,W	mov !RB,W	mov !RC,W	mov !RD,W	mov !RE,W
00h		Read T1CPL	Read T2CPL		
01h		Read T1CPH	Read T2CPH		
02h		Read T1R2CML	Read T2R2CML		
03h		Read T1R2CMH	Read T2R2CMH		
04h		Read T1R1CML	Read T2R1CML		
05h		Read T1R1CMH	Read T2R1CMH		
06h		Read T1CNTB	Read T2CNTB		
07h		Read T1CNTA	Read T2CNTA		
08h		Exchange CMP_B			
09h		Exchange WKPND_B			
0Ah		Write WKED_B			
0Bh		Write WKEN_B			
0Ch		Read ST_B	Read ST_C	Read ST_D	Read ST_E
0Dh	Read LVL_A	Read LVL_B	Read LVL_C	Read LVL_D	Read LVL_E
0Eh	Read PLP_A	Read PLP_B	Read PLP_C	Read PLP_D	Read PLP_E
0Fh	Read RA Direction	Read RB Direction	Read RC Direction	Read RD Direction	Read RE Direction
10h		Clear Timer T1	Clear Timer T2		
11h					
12h		Write T1R2CML	Write T2R2CML		
13h		Write T1R2CMH	Write T2R2CMH		
14h		Write T1R1CML	Write T2R1CML		
15h		Write T1R1CMH	Write T2R1CMH		
16h		Write T1CNTB	Write T2CNTB		
17h		Write T1CNTA	Write T2CNTA		
18h		Exchange CMP_B			

Table 5-2 MODE Register Settings for SX48/52BD

MODE Reg.	mov !RA,W	mov !RB,W	mov !RC,W	mov !RD,W	mov !RE,W
19h		Exchange WKPND_B			
1Ah		Write WKED_B			
1Bh		Write WKEN_B			
1Ch		Write ST_B	Write ST_C	Write ST_D	Write ST_E
1Dh	Write LVL_A	Write LVL_B	Write LVL_C	Write LVL_D	Write LVL_E
1Eh	Write PLP_A	Write PLP_B	Write PLP_C	Write PLP_D	Write PLP_E
1Fh	Write RA Direction	Write RB Direction	Write RC Direction	Write RD Direction	Write RE Direction

To modify the contents of the MODE register, you can move the desired value into W and then from W to the MODE register. However, if you only want to modify the lower four bits of the MODE register, you can use the “mov M,#lit” instruction, which takes just one clock cycle and preserves the contents of W.

5.3.3 Port Configuration Example

The following code example shows how to program the pullup control registers.

```

mov W,#$1E      ;MODE=1Eh to access port pullup registers
mov M,W         ;write 1Eh to MODE register

mov W,#$03      ;W = 0000 0011
mov !RA,W       ;disable pullups for A0 and A1

mov W,#$FF      ;W = 1111 1111
mov !RB,W       ;disable all pullups for B0-B7

mov W,#$00      ;W = 0000 0000
mov !RC,W       ;enable all pullups for C0-C7

```

First you load the MODE register with 1Eh to select access to the pullup control registers (PLP_A, PLP_B, and PLP_C). Then you use the “mov !rx,W” instructions to specify which port pins are to be connected to the internal pullup resistors. Setting a bit to 1 disconnects the corresponding pullup resistor, and clearing a bit to 0 connects the corresponding pullup resistor.

5.3.4 Port Configuration Registers

The port configuration registers controlled by the “mov !rx,W” instruction operate as described below.

RA through RE Data Direction Registers (MODE=1Fh)

Each register bit sets the data direction for one port pin. Set the bit to 1 to make the pin operate as a high-impedance input. Clear the bit to 0 to make the pin operate as an output.

PLP_A through PLP_E: Pullup Enable Registers (MODE=1Eh)

Each register bit determines whether an internal pullup resistor is connected to the pin. Set the bit to 1 to disconnect the pullup resistor or clear the bit to 0 to connect the pullup resistor.

LVL_A through LVL_E: Input Level Registers (MODE=1Dh)

Each register bit determines the voltage levels sensed on the input port, either TTL or CMOS, when the Schmitt trigger option is disabled. Program each bit according to the type of device that is driving the port input pin. Set the bit to 1 for TTL or clear the bit to 0 for CMOS.

ST_B through ST_E: Schmitt Trigger Enable Registers (MODE=1Ch)

Each register bit determines whether the port input pin operates with a Schmitt trigger. Set the bit to 1 to disable Schmitt trigger operation and sense either TTL or CMOS voltage levels; or clear the bit to 0 to enable Schmitt trigger operation.

WKEN_B: Wakeup Enable Register (MODE=1Bh)

Each register bit enables or disables the Multi-Input Wakeup/Interrupt (MIWU) function for the corresponding Port B input pin. Clear the bit to 0 to enable MIWU operation or set the bit to 1 to disable MIWU operation. For more information on using the Multi-Input Wakeup/Interrupt function, see [Section 4.4](#).

WKED_B: Wakeup Edge Register (MODE=1Ah)

Each register bit selects the edge sensitivity of the corresponding Port B input pin for MIWU operation. Clear the bit to 0 to sense rising (low-to-high) edges. Set the bit to 1 to sense falling (high-to-low) edges.

WKPND_B: Wakeup Pending Flag Register (MODE=19h)

When you access the WKPND_B register using the “mov !RB,W” instruction, the CPU does an exchange between the contents of W and WKPND_B. This feature lets you read the WKPND_B register contents. Each bit indicates the status of the corresponding MIWU pin. A bit set to 1 indicates that a valid edge has occurred on the corresponding MIWU pin, triggering a wakeup or interrupt. A bit set to 0 indicates that no valid edge has occurred on the MIWU pin. The WKPND_B register comes up with undefined value upon reset.

CMP_B: Comparator Register (MODE=18h)

When you access the CMP_B register using the “mov !RB,W” instruction, the CPU does an exchange between the contents of W and CMP_B. This feature lets you read the CMP_B register contents. Clear bit 7 to enable operation of the comparator. Clear bit 6 to place the comparator result on the RB0 pin. Bit 0 is a result flag that is set to 1 when the voltage on RB2 is greater than RB1, or cleared to 0 otherwise. (For more information using the comparator, see [Chapter 8](#).)

T2CNTB: Timer T2 Control B Register (MODE=16h)

This register is present only in the SX48/52BD. You access it with the “mov !RC,W” instruction. The seven low-order bits control the Timer T2 configuration as described in [Section 8.4.4](#). The high-order bit, called the PORTRD bit, selects the “port read” mode for all the I/O ports. Clear this bit to 0 to have the device read data from the port I/O pins directly. Set this bit to 1 to have the device read data from the port data registers.

5.3.5 Port Configuration Upon Reset

Upon reset, all the port control registers are initialized to FFh. Thus, each pin is configured to operate as a high-impedance input that senses TTL voltage levels, with no internal pullup resistor connected. The MODE register is initialized to 0Fh for the SX18/20/28AC or to 1Fh for the SX48/52BD, which allows immediate write access to the data direction registers with the “mov !rx,W” instruction.

5.3.6 Port Block Diagram

[Figure 5-1](#) is a block diagram showing the internal device hardware for one pin of Port B. This diagram will help you understand how the port operates and how to use it. Note that pin features related to the Multi-Input Wakeup/Interrupt function and the analog comparator function are not shown in this diagram.

The boxes labeled RB Direction, PLP_B, LVL_B, and ST_B represent individual control bits within the respective port control registers. The data registers and control registers are all mapped into the data memory space at address 06h. The control registers are accessed with the “mov !RB,W” instruction, with access controlled by the value in the MODE register; while the RB Data register bit is accessed by ordinary file register instructions such as “mov \$06,W”.

The port pin is configured to operate as either a high-impedance input or an output, as determined by the RB data register bit. When the pin is configured to operate as an input, the ST_B and LVL_B bits determine the type of input buffer used. The ST_B bit either enables or disables the Schmitt trigger input buffer. If the Schmitt trigger is disabled, the LVL_B bit selects either the TTL or CMOS buffer for sensing the input voltage levels on the pin.

When the device is configured to operate as an output, the bit in the RB data register is buffered and placed on the output pin. Reading from the port data address returns the actual logic level on the pin (in the default operating mode), even when the pin is configured to operate as an output.

The PLP_B bit either connects or disconnects the internal pullup resistor. If the pullup resistor is disconnected, an external pullup will be required.

The block diagram in [Figure 5-1](#) is for a Port B data pin, but the same diagram also applies to pins of the other ports, with one exception. Port A does not offer a Schmitt trigger input option, so it lacks the control register bit and logic associated with the Schmitt trigger buffer.

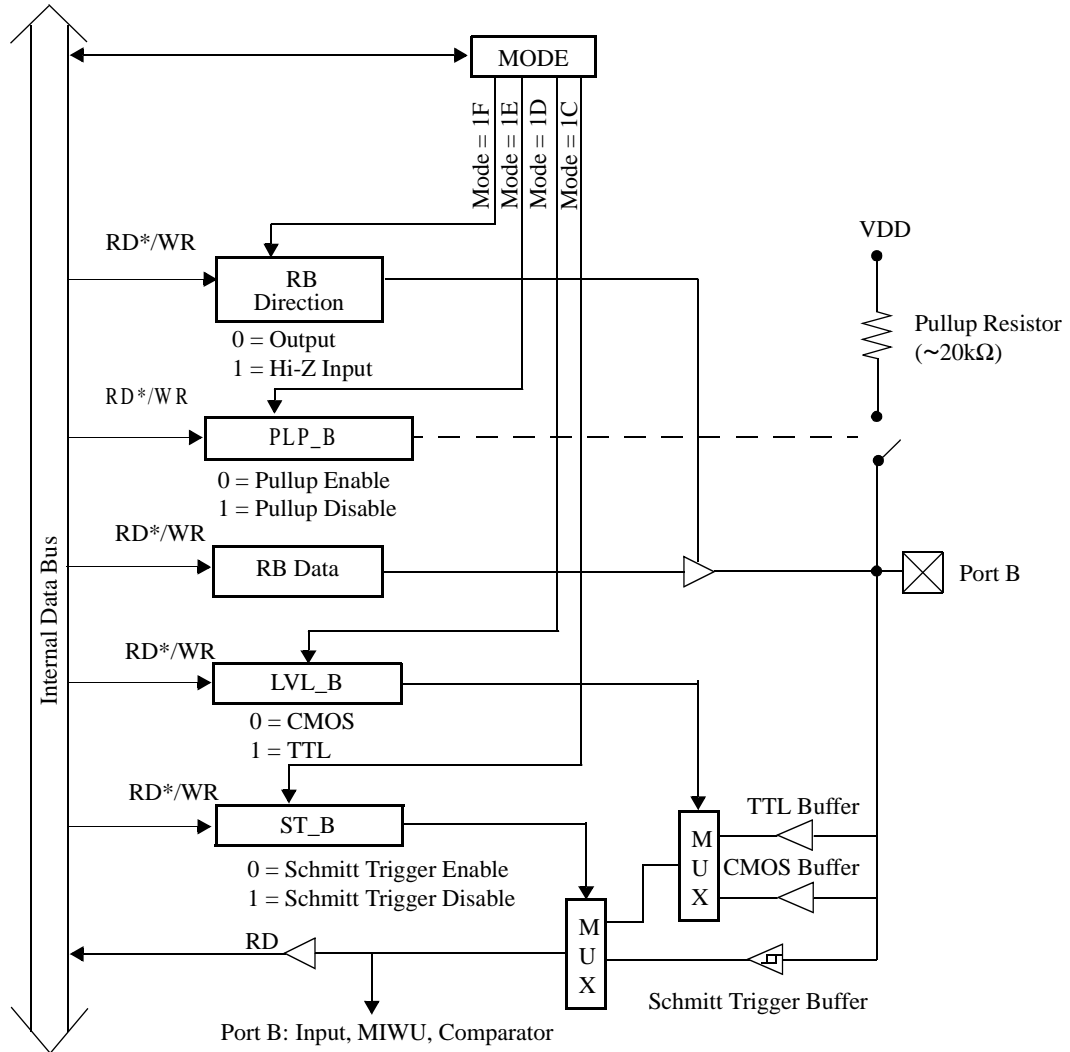

* RD (Read) on SX48BD/52BD only

Figure 5-1 Port B Pin Block Diagram



Chapter 6

Timers and Interrupts

6.1 Introduction

The SX core has two different timers: the Real-Time Clock/Counter (RTCC) and the Watchdog timer. The RTCC timer can be used to keep track of elapsed time or to count external events. The Watchdog timer provides an automatic escape route from infinite loops and other program errors. An RTCC timer overflow triggers an interrupt, whereas a Watchdog timer overflow triggers a device reset.

Some SX devices such as the SX48/52BC offer additional timers. These non-core features are described in separate chapters later in this manual.

The SX device supports interrupts from the RTCC circuit and from up to eight Multi-Input Wakeup pins in Port B. An interrupt causes a jump to the bottom of the program memory (address 0000h), where the interrupt service routine is located. The service routine is terminated by an RETI or RETIW instruction, which causes the device to jump back to the point in the program where the interrupt occurred and restore the program context at that point.

6.2 Real-Time Clock/Counter

The Real-Time Clock/Counter is a general-purpose timer that can be used to keep track of elapsed time or to keep a count of pulses received on the RTCC input pin. The RTCC register is a memory-mapped, 8-bit register that can keep a count up to 256. An 8-bit prescaler register can be used to extend the maximum count to 65,536.

[Figure 6-1](#) is a block diagram showing the RTCC circuit, including the RTCC register, the 8-bit prescaler register, the Watchdog timer (WDT) register, and the supporting multiplexers and configuration bits that control the RTCC timer.

The RTCC register is clocked (incremented) either by the internal instruction clock or by pulses received on the RTCC input pin. The choice is controlled by the RTS bit in the OPTION register. Set this bit to 1 to count pulses on the RTCC input pin, or clear this bit to 0 to count instruction cycles.

If you select the RTCC input pin as the clock source, the RTE_ES bit in the OPTION register specifies the type of transition sensed on the pin. Clear the bit to 0 to sense rising edges (low-to-high transitions) or set the bit to 1 to sense falling edges (high-to-low transitions) on the RTCC pin.

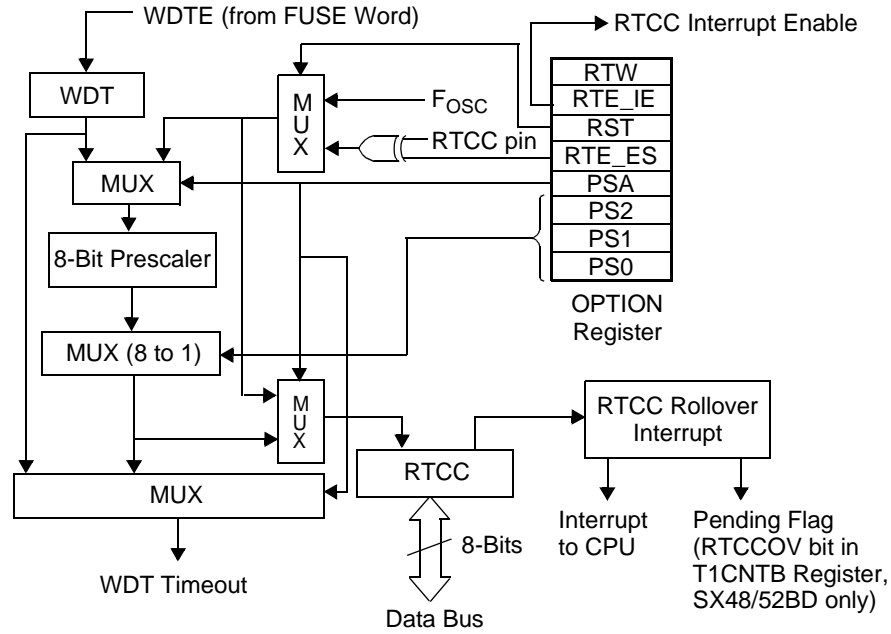

Figure 6-1 RTCC Block Diagram

6.2.1 Prescaler Register

The 8-bit prescaler register is shared between the Watchdog timer and RTCC circuit. It can be configured to operate as a prescaler for the RTCC circuit or as a postscaler for the Watchdog timer, but it cannot be used for both purposes at the same time. The selection between the two possible functions is controlled by the PSA (Prescaler Assignment) bit in the OPTION register.

If the prescaler register is used with the RTCC clock, it reduces the rate at which the RTCC register is incremented. The instruction cycles or external events being counted are used to increment the prescaler register, and transitions of a specified bit in the prescaler register are used to increment the RTCC register.

The rate at which the RTCC register is incremented is reduced by a factor determined by the PS2:PS0 bits in the OPTION register:

6.2.2 Maximum Count

The RTCC counter register is eight bits wide, so it can count up to 256 instruction cycles or external events. If you use the prescaler register and select a divide-by factor of 256, you can count up to 65,536 instruction cycles or events because the RTCC register is incremented only once per 256 instruction cycles or events.

The RTCC counter can be configured to trigger an interrupt each time it overflows from FFh to 00h. To enable this interrupt, clear the RTE_IE bit in the OPTION register. You can have the interrupt service routine increment a file register (or a set of cascaded file registers), and thereby keep track of any number of instruction cycles or events.

6.2.3 RTCC Operation as a Real-Time Clock or Timer

To use the RTCC circuit as a real-time clock, configure it to be incremented by the instruction clock. In that case, the RTCC counter is incremented at a fixed rate of once per instruction clock cycle. For example, if the instruction rate is 4 MHz, The RTCC counter is incremented at 4 MHz, or once per 250 nsec. The accuracy of the timer depends only on the accuracy of the clock that drives the SX device.

To increment the RTCC counter at slower rate, enable the prescaler register and specify the divide-by factor using the PS2:PS0 bits in the OPTION register.

To operate the RTCC as a count-down timer, initialize the RTCC register to the appropriate value and let the counter run. For example, to count 100 instruction cycles, load RTCC with the value 156 (decimal) using an instruction such as “mov \$01,#156”. The RTCC counter will then increment the register 100 times before it reaches the maximum value and rolls over back to zero, triggering an interrupt (if enabled by the RTE_IE bit in the OPTION register).

If you power down the device using the “SLEEP” instruction, the device clock is stopped, the RTCC counter stops operating, and the RTCC register contents are lost. Upon wakeup from the power down mode, the RTCC register contains unknown data.

On the SX18/20/28 devices, there is no interrupt pending bit to indicate the overflow occurrence. The RTCC register must be sampled by the program to determine any overflow occurrence.

6.2.4 RTCC Operation as an Event Counter

To use the RTCC circuit as an external event counter, configure it to be incremented by pulses on the RTCC input pin. Design the system to generate a pulse for each occurrence of the event, and feed that signal into the RTCC pin. Then the RTCC counter is incremented once for each occurrence of the external event. Use the RTE_ES bit in the OPTION register to specify the type of transition to be sensed on the RTCC pin (rising or falling edges).

To increment the RTCC counter at slower rate, enable the prescaler register and specify the divide-by factor using the PS2:PS0 bits in the OPTION register.

The RTCC circuit can count no more than one event per instruction cycle. Multiple edges received within a single instruction cycle are counted as a single event.

6.2.5 RTCC Overflow Interrupts

The device can be configured to generate an interrupt each time the RTCC register rolls over from FFh to 00h. To do this requires the following actions:

- Clear the OPTION_X bit in the FUSE word register when you program the device. This enables operation of the RTW and RTE_IE bits in the OPTION register.
- Have the software clear the RTE_IE bit in the OPTION register.

The SX48/52BC has an interrupt pending flag associated with RTCC rollover interrupts, called RTCCOV (RTCC Overflow), which is bit 7 in the T1CNTB register. The interrupt service routine can check this bit to determine whether an RTCC overflow caused the interrupt. The SX18/20/28 has no

such flag. In that case, the interrupt service routine should read the RTCC register to determine whether an RTCC rollover caused the interrupt. A register value of 00h (or a very low value) is an indicator that a rollover has just occurred.

6.3 Watchdog Timer

The Watchdog timer is a circuit that provides an automatic escape route from infinite loops and other abnormal program conditions. It can be enabled or disabled by the WDTE (Watchdog Timer Enable) bit in the FUSE word register. In the default configuration, the Watchdog timer is enabled.

The timer has an 8-bit register that is incremented by an independent on-chip oscillator, completely separate from the on-chip RC oscillator that can be used to drive the rest of the device. The counter counts up from 00h to FFh. When the counter rolls over from FFh to 00h (or rolls over the number of times programmed into the prescaler register), it generates a device reset and clears the TO (Timeout) flag in the STATUS register to indicate that a Watchdog timeout has occurred.

To prevent this automatic reset, the application program must periodically set the timer back to zero. This is accomplished by executing the “CLR !WDT” (clear Watchdog Timer) instruction, which clears the Watchdog timer register and prescaler register to zero. Executing this instruction is called “servicing” the Watchdog. The Watchdog timer register is not memory-mapped and is not accessible by any other means.

If the program gets stuck in an infinite loop, it is unlikely to service the Watchdog in that loop. In that case, when the Watchdog counts up to FFh and rolls over to 00h (or rolls over a specified number of times), the device is reset automatically, thus providing an escape from the infinite loop. A rollover also clears the TO (Timeout) flag.

The “CLR !WDT” instruction, in addition to clearing the Watchdog timer register, also sets the TO and PD flags to 1 in the STATUS register. The TO flag is cleared to 0 to indicate the occurrence of a Watchdog timeout. The PD flag is cleared to 0 by the “SLEEP” instruction to indicate that the device has been put into the power down mode.

6.3.1 Watchdog Timeout Period

The Watchdog oscillator has a nominal operating frequency of 14 kHz, or a period of 714 microseconds. At this rate, the 8-bit counter counts from 00h to FFh in 18 milliseconds. This amount of time is the default Watchdog timeout period. The application program needs to execute a “CLR !WDT” instruction at least once every 18 milliseconds to prevent a Watchdog reset.

The Watchdog timeout period can be increased by using the 8-bit prescaler register. This register can be configured to operate with either the Watchdog timer or RTCC circuit, but not both at the same time. This selection is controlled by the PSA (Prescaler Assignment) bit in the OPTION register.

If the prescaler register is used with the Watchdog timer, it actually operates as a postscaler that causes a device reset to occur after the 8-bit Watchdog register overflows a certain number of times. This increases the Watchdog timeout period by a factor determined by the PS2:PS0 bits in the OPTION

register. [Table 6-1](#) lists the PS2:PS0 settings and the corresponding divide-by factors and timeout periods.

Table 6-1 Watchdog Timeout Settings

PS2:PS0 (with PSA=1)	Watchdog Timer Output Divide-By Factor	Watchdog Timeout Period
000	1	0.018 sec
001	2	0.037 sec
010	4	0.073 sec
011	8	0.15 sec
100	16	0.29 sec
101	32	0.59 sec
110	64	1.17 sec
111	128	2.34 sec

6.3.2 Watchdog Operation in the Power Down Mode

The Watchdog timer operates even during the power down mode. This feature causes an automatic wakeup from the power down mode after the Watchdog timeout period has elapsed. The Watchdog circuit can continue to operate in power down mode because it is driven by its own on-chip oscillator.

If you do not need to use the Watchdog timer, you can disable it by clearing the WDTE bit in the FUSE word register. Doing so reduces power consumption in the power down mode because the Watchdog oscillator and counter no longer operate.

6.4 Interrupts

An interrupt is a condition that causes a CPU to stop its normal program execution and perform a separate “service” routine that handles the cause of the interrupt condition. An interrupt can occur at any point in the program and is typically triggered by an event that can happen at any time.

An interrupt causes the CPU to save the program context (program counter, W, STATUS, and FSR) and then jump to address 000h, where the interrupt service routine should be located. The service routine is terminated by a return-from-interrupt instruction, which restores the program context and causes the program to resume execution at the point where it was interrupted.

In the SX18/20/28AC devices, there are two possible causes of an interrupt:

- a rollover of the Real-Time Clock/Counter (RTCC)

- an interrupt signal received on a Port B input pin that has been configured for Multi-Input Wakeup/Interrupt operation

RTCC interrupts can be used to keep track of elapsed time (for example, to maintain a real-time clock that changes the displayed time once per second). Port B interrupts can be used to handle any type of external device that needs service, such as a hardware peripheral or a serial interface. The SX48/52BD devices have additional interrupt sources associated with the multi-function timers T1 and T2.

6.4.1 Single-Level Interrupt Operation

All interrupts are global in nature; that is, no interrupt has priority over another. Interrupts are handled sequentially. Once an interrupt is acknowledged, all subsequent global interrupts are disabled until return from servicing the current interrupt. The PC is pushed onto the single level interrupt stack, and the contents of the FSR, STATUS, and W registers are saved in their corresponding shadow registers. Bits PA0, PA1, and PA2, of the STATUS register are cleared after the STATUS register has been saved in its corresponding shadow register. The interrupt logic has its own single-level stack and is not part of the CALL subroutine stack. The vector for the interrupt service routines is address 0.

Once in the interrupt service routine, the user program must check all interrupt pending bits to determine the source of the interrupt. The interrupt service routine should clear the corresponding interrupt pending flag.

Normally it is a requirement for the user program to process every interrupt without missing any. To ensure this, the longest path through the interrupt routine must take less time than the shortest possible delay between interrupts.

The Multi-Input Wakeup/Interrupt circuit continues to operate during an interrupt service routine. It senses valid edges on the enabled wakeup/interrupt input pins and sets the WKPND_B pending flags accordingly. However, these interrupt events are not serviced until the current service routine is completed.

If more than one interrupt condition occurs during an interrupt service routine, the pending interrupts can be serviced in any order upon completion of the current interrupt service routine. There is no “priority” associated with different interrupt sources.

6.4.2 Interrupt Sequence

The following sequence takes place in processing an interrupt:

1. The interrupt condition occurs (either an RTCC rollover or a Multi-Input Wakeup/Interrupt signal on Port B). An interrupt is generated only if the applicable condition is enabled to operate as an interrupt.
2. The CPU automatically saves the current contents of the program counter (all 12 bits) and the W, STATUS, and FSR registers. It saves these register contents in a set of independent shadow registers, not in the program stack. All further interrupts are disabled.
3. The program jumps to address 000h, where the interrupt service routine should be located.

4. If the device is configured to accept different interrupts, the interrupt service routine should read the applicable registers (such as WKPND_B and T1CNTB) to determine the cause of the interrupt.
5. The interrupt service routine should perform the required task.
6. The interrupt service routine should end with a return-from-interrupt instruction, either RETI or RETIW.
7. The CPU automatically restores the contents of the program counter, W, STATUS, and FSR registers; and then resumes normal program execution at the point of interruption. If another interrupt condition occurred during the service routine, it immediately triggers a new interrupt at this time.

The interrupt response time is always three instruction cycles for an RTCC interrupt or five instruction cycles for a Multi-Input Wakeup interrupt. This is the amount of time it takes from detection of the interrupt condition to execution of the first instruction in the interrupt service routine.

[Figure 6-2](#) is a block diagram showing the internal logic of the interrupt generation circuit. An interrupt can be generated by either an RTCC rollover or a wakeup/interrupt signal on a Port B pin, if enabled by the appropriate bit in the OPTION register or STATUS register. A signal on a wakeup/interrupt pin of Port B generates an interrupt only during normal operation of the device, not in the power down mode.

6.4.3 RTCC Interrupts

The Real-Time Clock/Counter is a general-purpose timer that can be used to keep track of elapsed time or to keep a count of pulses received on the RTCC input pin. To enable RTCC interrupts, clear the RTE_EI bit in the OPTION register. In that case, the RTCC counter generates an interrupt each time it rolls over from FFh to 00h.

The SX48/52BC has an interrupt pending flag associated with RTCC rollover interrupts, called RTCCOV (RTCC Overflow), which is bit 7 in the T1CNTB register. The SX18/20/28 has no such flag. In that case, the interrupt service routine should read the RTCC register to determine whether an RTCC rollover caused the interrupt. A register value of 00h (or a very low value) is an indicator that a rollover has just occurred.

You can configure the RTCC circuit to count instruction cycles or external events, and you can specify the number of cycles or events that cause the RTCC counter to be incremented. For details, see [Section 6.2](#).

6.4.4 Port B Interrupts

The Multi-Input Wakeup/Interrupt circuit allows the Port B pins to be used as device inputs to trigger an interrupt from an external source. The same circuit is used for both wakeups and interrupts. In the power down state, a wakeup signal on a Port B pin wakes up the device and causes a device reset. The same signal received during normal device operation triggers an interrupt.

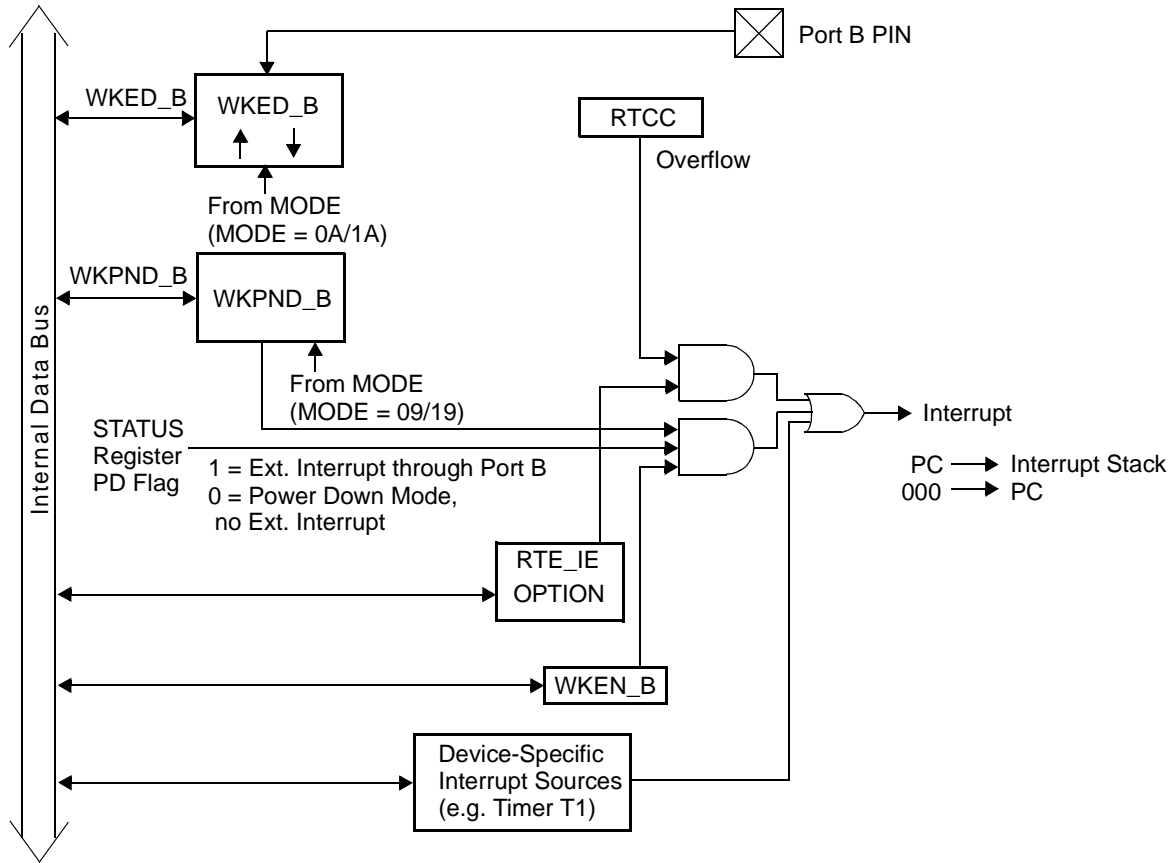

Figure 6-2 Interrupt Logic Block Diagram

You can configure any of the eight Port B pins to operate as wakeup/interrupt input pins and individually enable or disable the corresponding interrupt. On each enabled pin, you can choose to sense either rising or falling edges from the external interrupt source.

Each wakeup/interrupt pin has an associated pending flag to indicate whether a wakeup/interrupt signal has been detected. When Port B has been configured to use multiple Port B interrupt pins, the interrupt service routine should read the wakeup pending register to determine which Port B pin caused the interrupt.

For more information on using the Multi-Input Wakeup/Interrupt pins and the associated Port B registers, see [Section 4.4](#).

6.4.5 Device-Specific Interrupts

Some SX devices have on-chip peripheral modules that can generate interrupts. For example, the SX48/52BD device has two additional timers, T1 and T2, that can generate interrupts. These interrupt sources operate just like RTCC and Multi-Input Wakeup interrupts. They have their own interrupt configuration and enable bits.

For more information on using the interrupts associated with Timer T1 and Timer T2, see [Chapter 8](#).

6.4.6 Return-from-Interrupt Instructions

There are two return-from-interrupt instructions available:

- RETI (Return from Interrupt)
- RETIW (Return from Interrupt and adds W to RTCC)

Both of these instructions cause a return from the current interrupt service routine by restoring W, STATUS, FSR, and the program counter. The RETI instruction is a “plain” return from interrupt, whereas the RETIW also adds W to the RTCC register prior to the return.

The RETIW instruction adds W to RTCC before it restores W, STATUS, FSR, and the program counter. This allows RTCC to be restored to the value it contained at the time the main program was interrupted. To use this feature, the interrupt service routine should check the RTCC register at the beginning of the routine and again at the end of the routine, and then put the adjustment value into W before executing the RETIW instruction.

6.4.7 Interrupt Example

The following code example shows the part of an interrupt service routine that determines the cause of an interrupt and jumps to a processing routine based on the cause. In this example, the RB0 and RB1 pins are configured to operate as interrupt inputs and the RTCC counter is enabled to generate interrupts.

```

org 0           ;interrupt routine starts at address 000h
mov M,#$9      ;set up MODE register to read WKPND_B
clr W          ;clear W to zero
mov !RB,W      ;exchange contents of W and WKPND_B
and W,#$03     ;mask out unused bits from WKPND_B
               ;W now indicates cause of interrupt:
               ;00h = RTCC, 01h = RB0, or 02h = RB1
add $02,W      ;add W to program counter for indirect jump
jmp rtcc_i     ;W=00h, jump to RTCC interrupt service routine
jmp rb0_i      ;W=01h, jump to RB0 interrupt service routine
jmp rb1_i      ;W=02h, jump to RB1 interrupt service routine
rtcc_i
...           ;RTCC interrupt service routine here
reti          ;return from interrupt
rb0_i
...           ;RB0 interrupt service routine here
reti          ;return from interrupt
rb1_i
...           ;RB1 interrupt service routine here
reti          ;return from interrupt

```



Chapter 7

Analog Comparator

7.1 Introduction

The SX has an analog voltage comparator. The comparator circuit, when properly enabled and configured, compares the analog voltages supplied to two Port B input pins. The comparator determines which voltage is higher and reports the logical result in an internal register and also on a Port B output pin (if enabled for that purpose). The application program can read the result from the internal register, and an external device can read the result from the Port B output pin.

The comparator uses Port B pins RB2, RB1, and RB0. RB2 and RB1 are the comparator inputs, with RB2 operating as the positive input and RB1 operating as the negative input. If the voltage on RB2 is greater than the voltage on RB1, the result of a comparison operation is logic 1. Otherwise, the result is logic 0.

This result is reported on the RB0 pin, which is configured to operate as an output. If the result is only need by the SX software and not by an external device, then RB0 does not need to be used for the comparator function. Instead, it can be used as a general-purpose I/O pin or a Multi-Input Wakeup input pin.

7.2 Comparator Enable/Status Register (CMP_B)

The Comparator Enable/Status Register (CMP_B) is a Port B control register used to enable operation of the comparator, to enable the comparator output pin, and to read the comparison results. The register format is shown below.

CMP_EN	CMP_OE	Reserved					CMP_RES
7	6	5	4	3	2	1	0

There are three non-reserved bits in this register:

- $\overline{\text{CMP_EN}}$ (Comparator Enable). To enable operation of the comparator, clear this bit to 0. You must also configure RB2 and RB1 to operate as inputs by setting bit 2 and bit 1 in the RB Data Direction register.
- $\overline{\text{CMP_OE}}$ (Comparator Output Enable). Using the RB0 pin as a comparator output is optional. To do this, clear this bit to 0. You must also configure that pin to operate as an output by clearing bit 0 in the RB Data Direction register.

- **CMP_RES (Comparator Result).** To determine the comparator result, look at this bit the **CMP_B** register. A “1” indicates that the voltage on RB2 is greater than the voltage on RB1, and a “0” indicates the opposite. The comparator must be already enabled (**CMP_EN** bit cleared to 0) in order to read a valid result.

Upon power-up or reset, the **CMP_EN** and **CMP_OE** bits are both set to 1. This means that the comparator starts in the disabled state.

7.2.1 Accessing the **CMP_B** Register

Like all port configuration registers, the **CMP_B** register is accessed by the “**mov !rx,W**” instruction in conjunction with an appropriate **MODE** register setting. For example, you can access the **CMP_B** register using the following commands:

```

mov  M,#$8      ;set MODE register to access CMP_B
mov  W,#$00     ;clear W
mov  !RB,W      ;enable comparator and its output
...            ;delay after enabling comparator for response

mov  M,#$8      ;set MODE register to access CMP_B
mov  W,#$00     ;clear W
mov  !RB,W      ;enable comparator and its output and
                ;also read CMP_B (exchange W and CMB_B)
and  W,#$01     ;set/clear Z flag based on comparator result
snb  $03.2     ;test Z flag in STATUS reg (0 => RB2<RB1)
jmp  rb2_hi     ;jump only if RB2>RB1
...

```

To access the **CMP_B** register, you should load the **MODE** register with either 08h or 18h. The four high-order bits of the **MODE** register are “don’t care” bits. The “**mov M,#\$8**” instruction moves the value 8h into the four low-order bit positions of the **MODE** register.

When you use the “**MOV !RB,W**” instruction to access the **CMP_B** register, it performs an exchange of data between **W** and port control register. (An exchange of this type is performed only when you access the **CMP_B** or **WKPND_B** register.) In the programming example above, the “**MOV !RB,W**” instruction writes 00h into the **CMP_B** register, and simultaneously reads the contents of **CMP_B** into **W**.

7.3 Comparator Operation

Figure 7-1 is a block diagram showing the internal hardware of the comparator circuit. The two analog inputs to the comparator are the RB2 and RB1 pins. Operation of the comparator is enabled by the **CMP_RES** bit and operation of the RB0 pin as the comparator output is enabled by the **CMP_OE** bit. The comparator result appears in the **CMP_RES** bit position, whether or not the RB0 output pin is used with the comparator. Read/write access to the **CMP_B** register is enabled when the **MODE** register contains 08h or 18h.

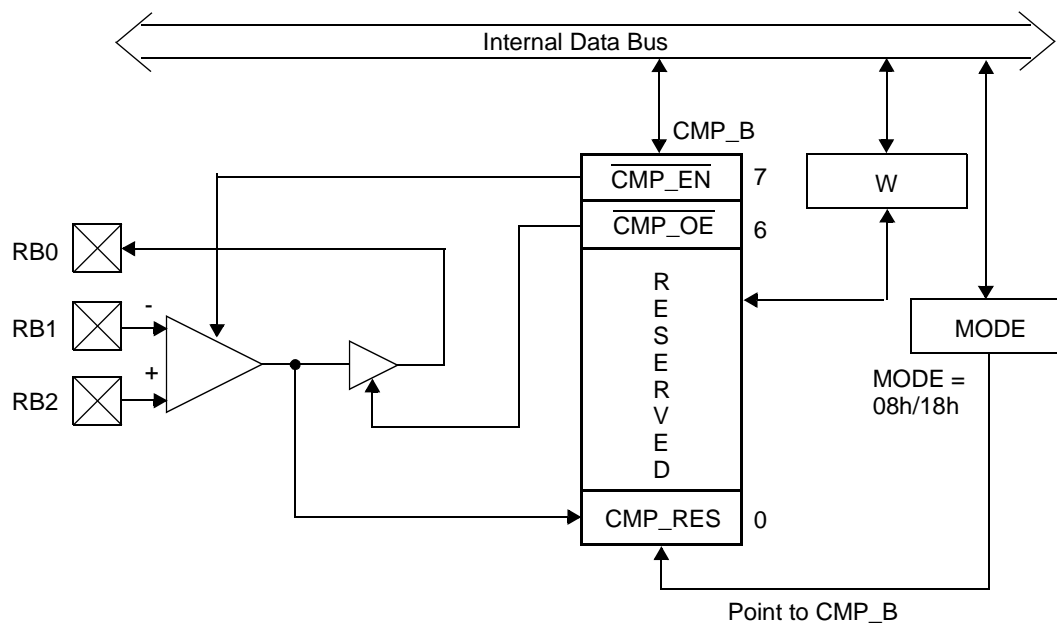

Figure 7-1 Comparator Block Diagram

As long as the comparator is enabled, it operates continuously and reports its result in the `CMP_RES` bit of the `CMP_B` register and on the `RB0` pin (if enabled for that purpose). To reduce unnecessary power consumption during the power down state, you should disable the comparator before using the “sleep” instruction.

The comparator takes some time to respond after it is enabled and after a change in the analog input voltages. For details, see the comparator DC and AC specifications in the device data sheet.



Chapter 8

Multi-Function Timers

8.1 Introduction

Some SX devices such as the SX48/52BD have a set of on-chip multi-function timers in addition to the standard RTCC and Watchdog timers found in all SX devices. The SX48/52BD has two such multi-function timers, designated T1 and T2. These versatile, programmable timers reduce the software burden on the CPU in real-time control applications such as PWM generation, motor control, triac control, variable-brightness display control, sine wave generation, and data acquisition.

Each timer consists of a 16-bit counter register supported by a 16-bit capture register and a 16-bit comparison register. Each timer uses up to four I/O pins: one clocking input, two capture inputs, and one timer output. The timer I/O pins are alternate functions of Port B pins for timer T1 and Port C pins for Timer T2.

Figure 8-1 is a block diagram showing the registers and I/O pins of one timer. The 16-bit free-running timer/counter register is initialized to 0000h upon reset and counts upward continuously. It is clocked either by an external signal provided on an I/O pin or by the on-chip system clock divided by a programmable 8-bit prescaler register.

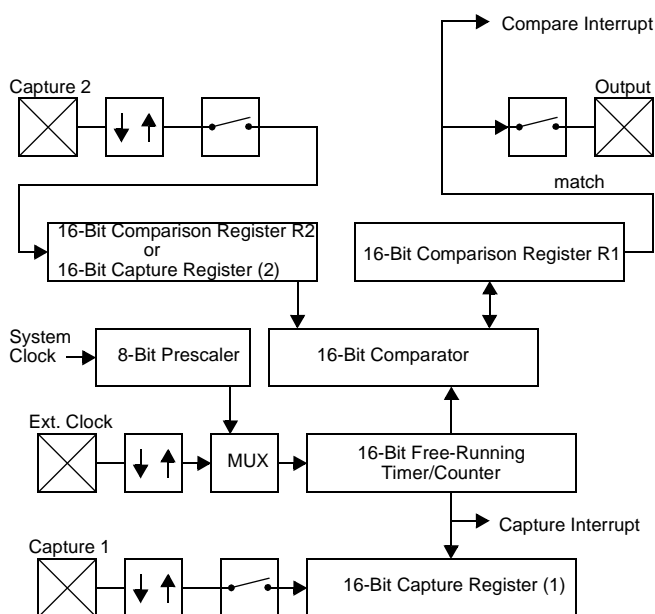

Figure 8-1 Multi-Function Timer Block Diagram

The CPU can access the R1, R2, and Capture registers by using the “mov !RB,W” instruction for T1 or the “mov !RC,W” instruction for T2. The other timer registers are not directly accessible.

You can configure the timer to generate an interrupt upon overflow from FFFFh to 0000h, upon a match between the counter value and a programmed comparison value, or upon the occurrence of a valid capture signal on either of two capture inputs.

8.2 Timer Operating Modes

Each timer can be configured to operate in one of the following modes:

- Pulse Width Modulation (PWM) mode
- Software Timer mode
- External Event mode
- Capture/Compare mode

8.2.1 PWM Mode

In the Pulse Width Modulation (PWM) mode, the timer generates an output signal having a programmable frequency and duty cycle. To use this mode, you load the two 16-bit comparison registers, R1 and R2, with the number of timer clock cycles that you want the output signal to be high and low.

The timer starts from zero and counts up until it reaches the value in R1. At that point, it generates an interrupt (if enabled), toggles the output signal, and starts counting from zero again. The second time, it counts up until it reaches the value in R2. At that point, it again generates an interrupt (if enabled), toggles the output signal, and starts counting from zero again. This process is repeated continuously, alternating between R1 and R2 to obtain the value at which to toggle the output signal and return the counter to zero. The values of R1 and R2 establish the duty cycle and frequency of the output signal. If R1 and R2 contain the same value, the resulting output signal is a square wave.

In the PWM mode, the timer is clocked by the on-chip system clock divided by an 8-bit prescaler value. The divide-by factor can be set to any power-of-2 from 1 to 256. Thus, the period of the timer clock can be set from 1 to 256 times the system clock period.

8.2.2 Software Timer Mode

The Software Timer mode is the same as the PWM mode, except that the timer does not toggle the output signal. Instead, the application program takes action in response to the interrupts generated upon each match between the counter and the contents of the active comparison value in either R1 or R2. The software can determine the cause of each interrupt by checking the timer interrupt pending flags. There is a different flag bit associated with each type of event (R1 match, R2 match, or overflow).

8.2.3 External Event Mode

The External Event mode is the same as the PWM mode, except that the counter register is clocked by an external signal provided on an input pin rather than by the system clock. This mode can be used to count the occurrences of external events. The input pin can be configured to sense either rising or falling edges.

8.2.4 Capture/Compare Mode

In the Capture/Compare mode, the counter counts upward continuously without interruption. A valid transition received on either of two input pins causes the current value of the counter to be captured in an associated capture register. This capture feature can be used to keep track of the elapsed time between successive external events. In addition, the timer continuously compares the counter value against the value programmed into the R1 register. Each time a match occurs, it toggles the timer output pin, and also generates an interrupt (if enabled). The timer continues to count upward after a match occurs (unlike the PWM mode, which resets the counter to zero when a match occurs).

In the Capture/Compare mode, the timer is clocked by the on-chip system clock divided by an 8-bit prescaler value. The divide-by factor can be set to any power-of-2 from 1 to 256.

The two input capture pins are designated Capture 1 and Capture 2. They can be configured to sense either rising or falling edges. The Capture 1 pin captures the counter value in a dedicated 16-bit capture register, a read-only register. The Capture 2 pin captures the counter value in the R2 register. The occurrence of a capture event also generates an interrupt (if enabled) and sets an associated interrupt pending flag.

Overflow of the counter from FFFFh to 0000h also generates an interrupt (if enabled) and sets an associated interrupt pending flag. Because the counter is free-running, an overflow can occur at any time. In cases where the time between successive capture events might exceed 65,536 counts of the timer, the software should keep track of the number of overflows between successive events in order to determine the true amount of time between such events.

An occurrence of a match between the counter value and the programmed value in the R1 register toggles the timer output pin. It also generates an interrupt (if enabled) and sets an associated interrupt pending flag. The timer continues to run freely without being reset to zero. Therefore, if you want to have a fixed timeout period for this interrupt, the interrupt service routine must write a new value into R1 each time a match occurs.

8.3 Timer Pin Assignments

The following table lists the I/O port pins associated with the Timer T1 and Timer T2 I/O functions.

Table 8-1 Timer T1/T2 Pin Assignments

I/O Pin	Timer T1/T2 Function
RB4	Timer T1 Capture Input 1
RB5	Timer T1 Capture Input 2
RB6	Timer T1 PWM/Compare Output
RB7	Timer T1 External Event Clock Source
RC0	Timer T2 Capture Input 1
RC1	Timer T2 Capture Input 2
RC2	Timer T2 PWM/Compare Output
RC3	Timer T2 External Event Clock Source

8.4 Timer Control Registers

There are two 8-bit control registers associated with each timer, called the Control A and Control B registers. The Control A register contains the interrupt enable bits and interrupt flag bits associated with the timer. (Interrupts are caused by comparison, capture, and overflow events.) The Control B register contains bits for setting the timer operating mode, the clock prescaler divide-by factor, and the input signal edge sensitivity. Each Control B register also contains one device configuration bit not related to operation of the multi-function timers.

The register formats are shown in the following diagrams.

8.4.1 Timer T1 Control A Register (T1CNTA)

T1CPF2	T1CPF1	T1CPIE	T1CMF2	T1CMF1	T1CMIE	T1OVF	T1OVIE
7	6	5	4	3	2	1	0

Table 8-2 T1CNTA Register Bits

Bit Name	Description
T1CPF2	Timer T1 Capture Flag 2. In Capture/Compare mode, this flag is automatically set to 1 when a capture event occurs on the Capture 2 pin of Timer T1 (pin RB5). It stays set until cleared by the software.
T1CPF1	Timer T1 Capture Flag 1. In Capture/Compare mode, this flag is automatically set to 1 when a capture event occurs on the Capture 1 pin of Timer T1 (pin RB4). It stays set until cleared by the software.
T1CPIE	Timer T1 Capture Interrupt Enable. Set this bit to 1 to enable capture interrupts for Timer T1 in Capture/Compare mode. In that case, an interrupt will occur each time a valid edge is received on the Capture 1 or Capture 2 pin of Timer T1. Clear this bit to 0 to disable capture interrupts.
T1CMF2	Timer T1 Comparison Flag 2. This flag is automatically set to 1 when the contents of the timer counter match the contents of R2, when R2 is the active comparison register. The flag stays set until it is cleared by the software.
T1CMF1	Timer T1 Comparison Flag 1. This flag is automatically set to 1 when the contents of the timer counter match the contents of R1, when R1 is the active comparison register. The flag stays set until it is cleared by the software.
T1CMIE	Timer T1 Comparison Interrupt Enable. Set this bit to 1 to enable comparison interrupts for Timer T1. In that case, an interrupt will occur each time the contents of the timer counter match the contents of the active comparison register (R1 or R2) of Timer T1. Clear this bit to 0 to disable comparison interrupts.
T1OVF	Timer T1 Overflow Flag. This flag is automatically set to 1 when the timer counter overflows from FFFFh to 0000h. The flag stays set until it is cleared by the software.
T1OVIE	Timer T1 Overflow Interrupt Enable. Set this bit to 1 to enable overflow interrupts for Timer T1. In that case, an interrupt will occur each time Timer T1 overflows. Clear this bit to 0 to disable overflow interrupts.

8.4.2 Timer T1 Control B Register (T1CNTB)

RTCCOV	T1CPEDG	T1EXEDG	T1PS2-T1PS0			T1MC1-T1MC0	
7	6	5	4	3	2	1	0

Table 8-3 T1CNTB Register Bits

Bit Name	Description
RTCCOV	RTCC Overflow Flag. This flag is automatically set to 1 when the Real-Time Clock/Counter (RTCC) overflows from FFh to 00h. This flag stays set until it is cleared by the software. Note that this flag is not related to multi-function timers T1 and T2.
T1CPEDG	Timer T1 Capture Edge. This bit sets the edge sensitivity of the Timer T1 input capture pins, Capture 1 and Capture 2 (RB4 and RB5). Set this bit to 1 to sense positive-going (low-to-high) edges. Clear this bit to 0 to sense negative-going (high-to-low) edges.
T1EXEDG	Timer T1 External Event Clock Edge. This bit sets the edge sensitivity of the Timer T1 input used to count external events (RB7). Set this bit to 1 to sense positive-going (low-to-high) edges. Clear this bit to 0 to sense negative-going (high-to-low) edges.

Table 8-3 T1CNTB Register Bits

Bit Name	Description
T1PS2-T1PS0	<p>Timer T1 Prescaler Divider field. This 3-bit field specifies the divide-by factor for generating the timer clock from the on-chip system clock:</p> <p>000 = divide by 1 001 = divide by 2 010 = divide by 4 011 = divide by 8 100 = divide by 16 101 = divide by 32 110 = divide by 64 111 = divide by 128</p> <p>For example, setting this field to 010 sets the divide-by factor to 4, which means that the T1 counter register is incremented once every four system clock cycles.</p>
T1MC1-T1MC0	<p>Timer T1 Mode Control field. This 2-bit field specifies the Timer T1 operating mode as follows:</p> <p>00 = Software Timer mode 01 = PWM mode 10 = Capture/Compare mode 11 = External Event mode</p>

8.4.3 Timer T2 Control A Register (T2CNTA)

T2CPF2	T2CPF1	T2CPIE	T2CMF2	T2CMF1	T2CMIE	T2OVF	T2OVIE
7	6	5	4	3	2	1	0

Table 8-4 T2CNTA Register Bits

Bit Name	Description
T2CPF2	Timer T2 Capture Flag 2. In Capture/Compare mode, this flag is automatically set to 1 when a capture event occurs on the Capture 2 pin of Timer T2 (pin RC1). It stays set until cleared by the software.
T2CPF1	Timer T2 Capture Flag 1. In Capture/Compare mode, this flag is automatically set to 1 when a capture event occurs on the Capture 1 pin of Timer T2 (pin RC1). It stays set until cleared by the software.
T2CPIE	Timer T2 Capture Interrupt Enable. Set this bit to 1 to enable capture interrupts for Timer T2 in Capture/Compare mode. In that case, an interrupt will occur each time a valid edge is received on the Capture 1 or Capture 2 pin of Timer T2. Clear this bit to 0 to disable capture interrupts.
T2CMF2	Timer T2 Comparison Flag 2. This flag is automatically set to 1 when the contents of the timer counter match the contents of R2, when R2 is the active comparison register. The flag stays set until it is cleared by the software.
T2CMF1	Timer T2 Comparison Flag 1. This flag is automatically set to 1 when the contents of the timer counter match the contents of R1, when R1 is the active comparison register. The flag stays set until it is cleared by the software.

Table 8-4 T2CNTA Register Bits

Bit Name	Description
T2CMIE	Timer T2 Comparison Interrupt Enable. Set this bit to 1 to enable comparison interrupts for Timer T2. In that case, an interrupt will occur each time the contents of the timer counter match the contents of the active comparison register (R1 or R2) of Timer T2. Clear this bit to 0 to disable comparison interrupts.
T2OVF	Timer T2 Overflow Flag. This flag is automatically set to 1 when the timer counter overflows from FFFFh to 0000h. The flag stays set until it is cleared by the software.
T2OVIE	Timer T2 Overflow Interrupt Enable. Set this bit to 1 to enable overflow interrupts for Timer T2. In that case, an interrupt will occur each time Timer T2 overflows. Clear this bit to 0 to disable overflow interrupts.

8.4.4 Timer T2 Control B Register (T2CNTB)

PORTRD	T2CPEDG	T2EXEDG	T2PS2-T2PS0			T2MC1-T2MC0	
7	6	5	4	3	2	1	0

Table 8-5 T2CNTB Register Bits

Bit Name	Description
PORTRD	Port Read mode. This bit determines how the device reads data from its I/O ports (Port A through Port E). Clear this bit to 0 to have the device read data from the port I/O pins directly. Set this bit to 1 to have the device read data from the port data registers. Under normal conditions, it should not matter which method you use to read the port data. However, if a port pin is configured as an output and an external circuit forces the pin to the wrong value, the value read from the port will depend on the reading mode used. Note that this control bit is not related to multi-function timers T1 and T2.
T2CPEDG	Timer T2 Capture Edge. This bit sets the edge sensitivity of the Timer T2 input capture pins, Capture 1 and Capture 2 (RC0 and RC1). Set this bit to 1 to sense positive-going (low-to-high) edges. Clear this bit to 0 to sense negative-going (high-to-low) edges.
T2EXEDG	Timer T2 External Event Clock Edge. This bit sets the edge sensitivity of the Timer T2 input used to count external events (RC3). Set this bit to 1 to sense positive-going (low-to-high) edges. Clear this bit to 0 to sense negative-going (high-to-low) edges.

Table 8-5 T2CNTB Register Bits

Bit Name	Description
T2PS2-T2PS0	<p data-bbox="430 283 1458 346">Timer T2 Prescaler Divider field. This 3-bit field specifies the divide-by factor for generating the timer clock from the on-chip system clock:</p> <ul data-bbox="430 378 641 630" style="list-style-type: none">000 = divide by 1001 = divide by 2010 = divide by 4011 = divide by 8100 = divide by 16101 = divide by 32110 = divide by 64111 = divide by 128 <p data-bbox="430 661 1404 724">For example, setting this field to 010 sets the divide-by factor to 4, which means that the T2 counter register is incremented once every four system clock cycles.</p>
T2MC1-T2MC0	<p data-bbox="430 751 1458 783">Timer T2 Mode Control field. This 2-bit field specifies the Timer T2 operating mode as follows:</p> <ul data-bbox="430 787 738 903" style="list-style-type: none">00 = Software Timer mode01 = PWM mode10 = Capture/Compare mode11 = External Event mode



Scenix Semiconductor, Inc
3160 De La Cruz Boulevard
Suite 200
Santa Clara, CA 95054

Contact: sales@scenix.com
support@scenix.com
<http://www.scenix.com>

tel.: (408) 327 - 8888

fax: (408) 327 - 8880

Lit. No. SXL-UM01-02