



CML Semiconductor Products

PRODUCT INFORMATION

FX118 Duplex Frequency Inverter for Cordless Telephones

Publication D/118/3 July 1994

Features/Applications

- Frequency Inversion Scrambling
- Full-Duplex Operation
- High Baseband and Carrier Rejection
- Audio Lowpass and Bandpass Filtering On-Chip
- Xtal Oscillator Stability
- Low Power Requirement (3.0 Volt Minimum)
- Cordless Telephones
- Base and Handheld Applications
- Input Gain Adjustment
- Plastic DIL and S.O.I.C. Package Styles

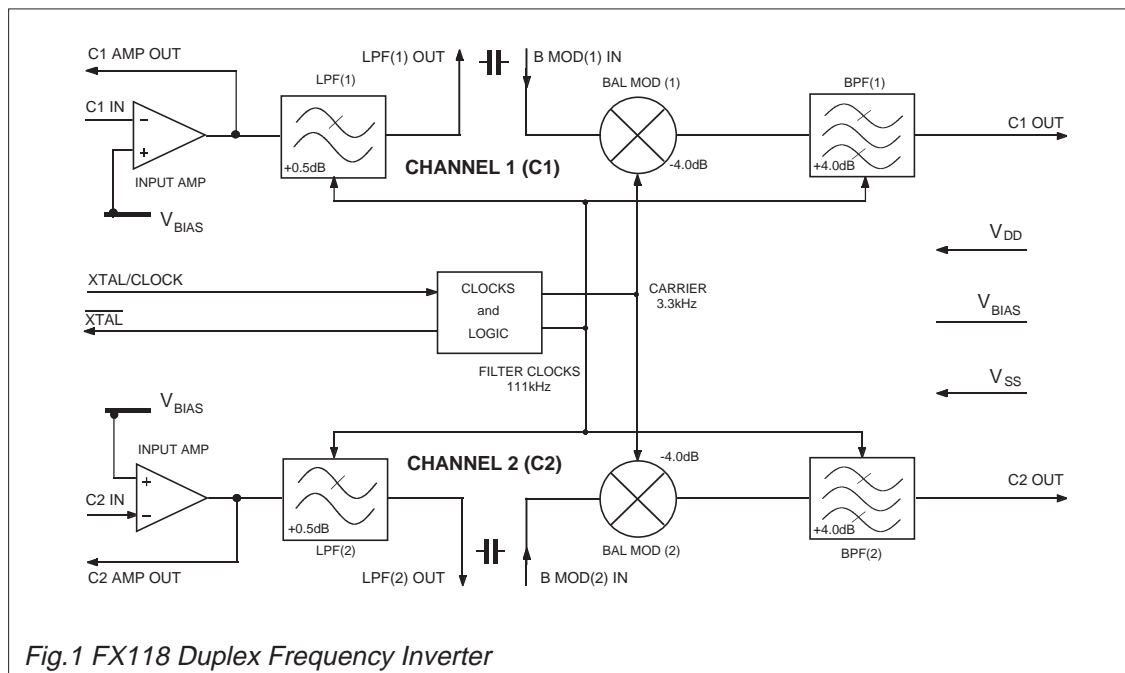

FX118

Brief Description

The FX118 is a low-power, full-duplex frequency inverter available to provide voice privacy for cordless telephone systems by mixing the incoming audio with an internally produced carrier frequency (3.3kHz).

This chip contains two completely separate audio channels (C1 and C2) each comprising a "component-adjustable" input amplifier, a 10th-order lowpass filter, a balanced modulator and a 14th-order bandpass filter output.

The on-chip modulation process has the properties of high baseband and carrier frequency rejection which when combined with high-order output filtering, produces a high-quality recovered voiceband audio.

The frequency stability of the FX118 is achieved by an on-chip oscillator employing an external 4.433619MHz Xtal or clock input to produce the common carrier frequency and the sampling clocks for the switched capacitor low and bandpass filters.

This microcircuit has a low power requirement of 3.0 volts (min.) and is encapsulated in either 16-pin DIL or small outline SMD (S.O.I.C.) plastic packages both of which are of a physical size suitable for either base or handset type telephone instruments as well as battery-portable and mobile communications systems.

Pin Number

Function

FX118DW FX118P	
1	Xtal: Output of clock oscillator inverter.
2	No Internal Connection: It is recommended that, to improve noise conditions, this pin is connected to V_{SS} .
3	LPF(1) Out: The output of the Channel 1 Lowpass Filter. It is to be coupled to “B Mod(1) In” via a 1.0 μ F capacitor – see Figure 2.
4	B Mod(1) In: The input to Channel 1 balanced modulator. Internally biased at $V_{DD}/2$ it is to be coupled to “LPF(1)” via a 1.0 μ F capacitor – see Figure 2.
5	V_{SS}: Negative supply (GND).
6	C1 Out: The analogue output of Channel 1.
7	C1 Amp Output: Channel 1 amplifier with external components (see Figure 2) can be used to provide gain in the signal path.
8	C1 In: The negative input of Channel 1 Amplifier. Recommended external components are shown in Figure 2.
9	C2 In: The negative input of Channel 2 Amplifier. Recommended external components are shown in Figure 2.
10	C2 Amp Output: Channel 2 amplifier with external components (see Figure 2) can be used to provide gain in the signal path.
11	C2 Out: The analogue output of Channel 2.
12	V_{BIAS}: The internal analogue bias line at $V_{DD}/2$. It should be decoupled to V_{SS} via a 1.0 μ F or greater capacitor. See Figure 2.
13	B Mod(2) In: The input to Channel 2 balanced modulator. Internally biased at $V_{DD}/2$ it is to be coupled to “LPF(2)” via a 1.0 μ F capacitor – see Figure 2.
14	LPF(2) Out: The output of the Channel 2 Lowpass Filter. It is to be coupled to “B Mod(2) In” via a 1.0 μ F capacitor – see Figure 2.
15	V_{DD}: The positive supply rail. A single positive supply voltage (3.0v – 5.0v) is required. Levels and voltages within the Duplex Frequency Inverter are dependent upon this supply.
16	Xtal/Clock: 4.433619 MHz Xtal or externally derived clock is injected at this pin. See Figure 2. Operation of the FX118 without a Xtal or clock input may cause device damage.

Application Information

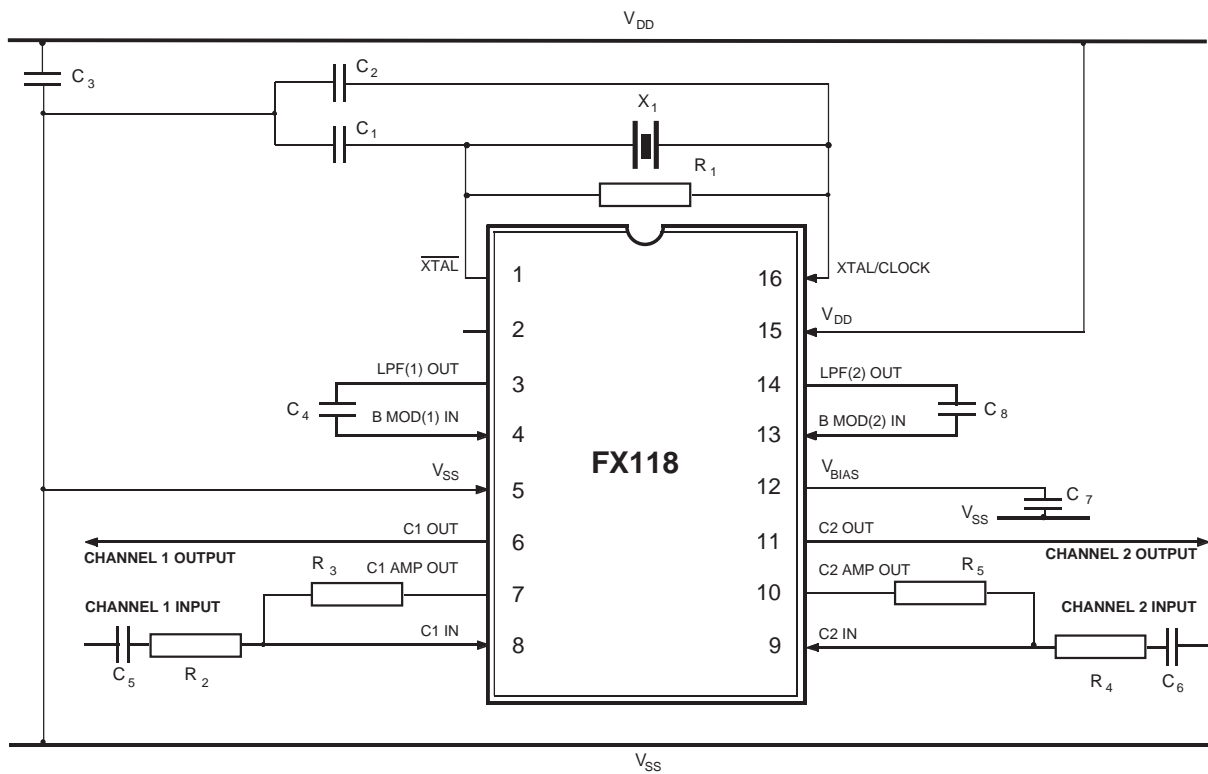

Component	Value	Component	Value	Component	Value
R ₁	= 1.0MΩ	C ₂	= 33pF	C ₇	= 1.0μF
R ₂ , R ₃ , C ₅	See Note	C ₃	= 0.47μF	C ₈	= 1.0μF
R ₄ , R ₅ , C ₆	See Note	C ₄	= 1.0μF	X ₁	= 4.433619MHz
C ₁	= 47pF	Tolerances C = ±20% R = ±10%			

- NOTES**
- Configurations R₂, R₃, C₅ and R₄, R₅, C₆ should be chosen with respect to the specific application.
 - Operation of any CML microcircuit without a Xtal or clock input may cause device damage. To minimise damage in the event of a Xtal/drive failure, it is recommended that the power rail (V_{DD}) is fitted with a current limiting device (resistor or fast-reaction fuse).

Fig.2 Recommended External Components

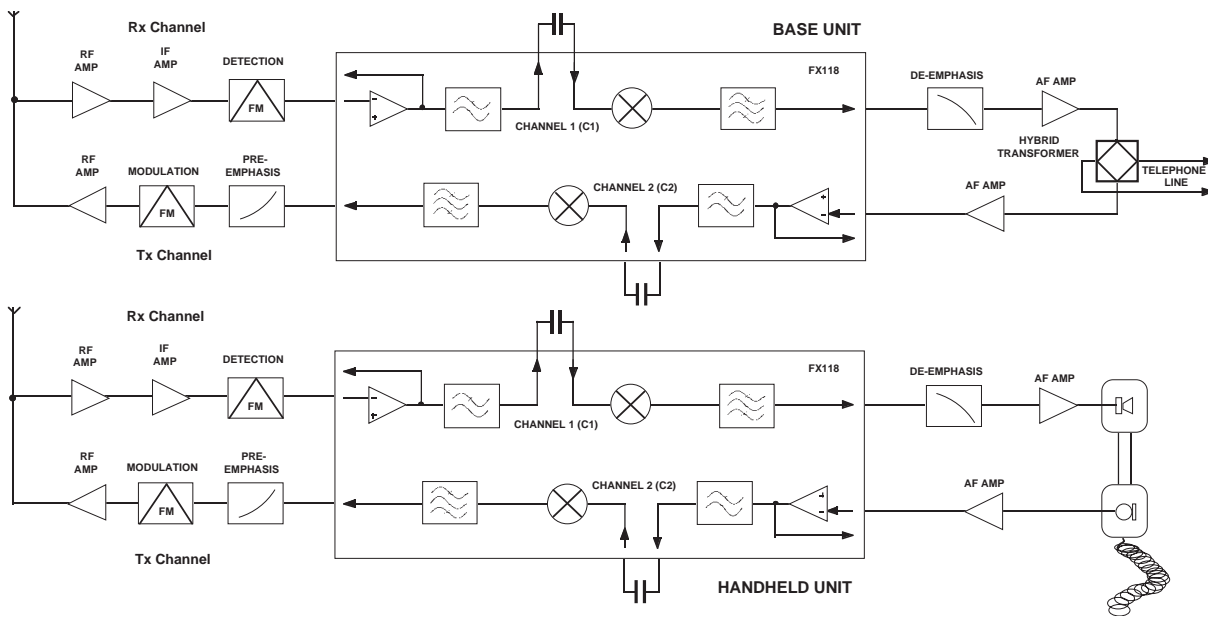
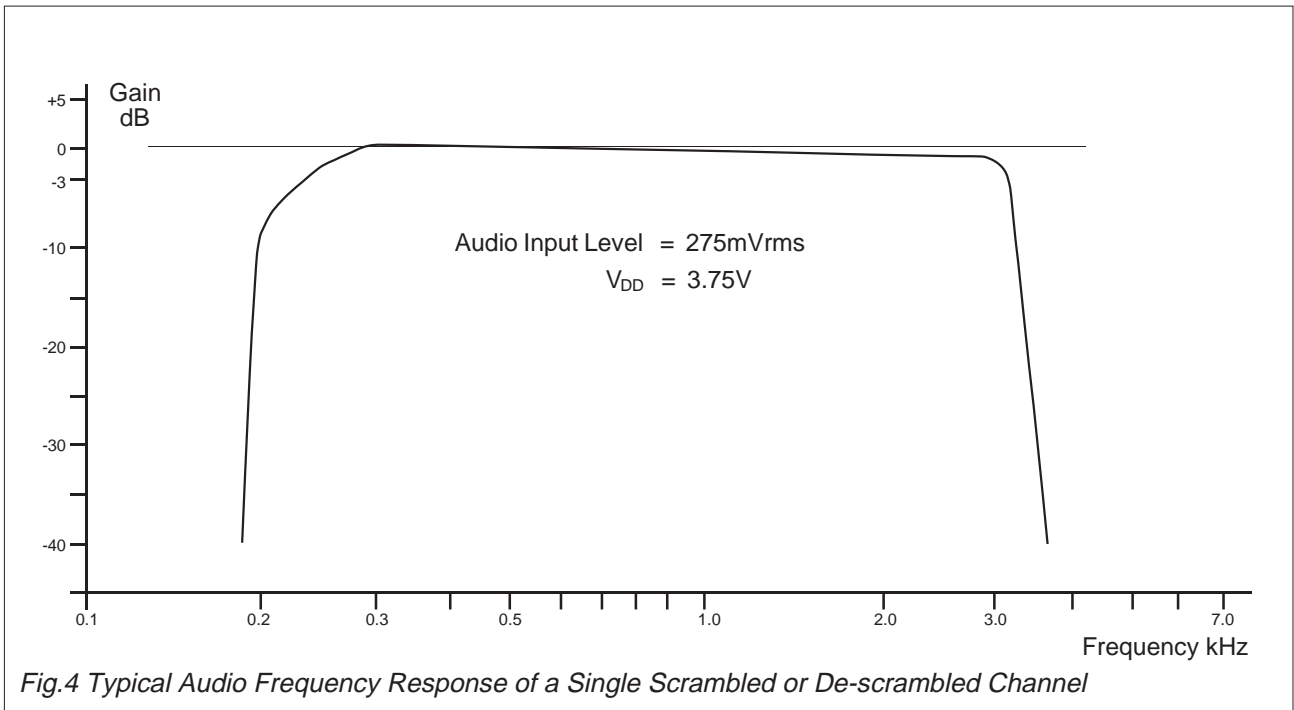

Fig.3 Example of the FX118 Employed in a Cordless Telephone Application

Application Information



System Gains

When calculating the external components for the operation of the FX118 the following points should be considered:

- (a) The Input Lowpass Filter has a (typical) gain of 0.5dB.
- (b) The Balanced Modulator has a (typical) attenuation of 4.0dB.
- (c) The Output Bandpass Filter has a (typical) gain of 4.5dB.

How the Inverter Works

Carrier Frequency *minus* Input Voice Frequency *equals* Scrambled Voice Frequency

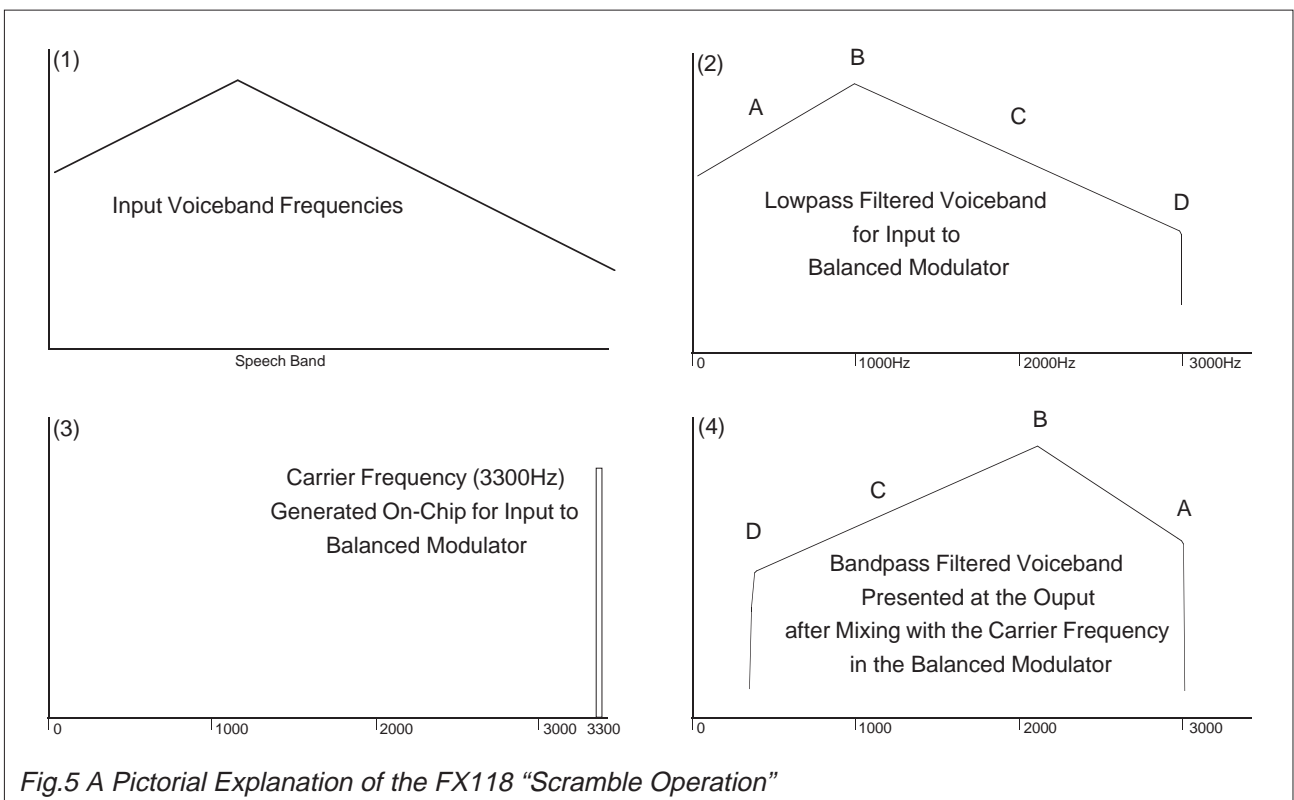

Specification

Absolute Maximum Ratings

Exceeding the maximum rating can result in device damage. Operation of the device outside the operating limits is not implied.

Supply voltage		-0.3 to 7.0V
Input voltage at any pin (ref $V_{SS} = 0V$)		-0.3 to ($V_{DD} + 0.3V$)
Sink/source current (supply pins)		+/- 30mA
(other pins)		+/- 20mA
Total device dissipation @ $T_{AMB} 25^{\circ}C$		800mW Max.
Derating		10mW/ $^{\circ}C$
Operating temperature range:	FX118DW/P	-40 $^{\circ}C$ to +85 $^{\circ}C$
Storage temperature range:	FX118DW/P	-40 $^{\circ}C$ to +85 $^{\circ}C$

Operating Limits

All device characteristics are measured under the following conditions unless otherwise specified:

$V_{DD} = 3.75V$. $T_{AMB} = 25^{\circ}C$. Xtal/Clock $f_0 = 4.433619MHz$. Audio level 0dB ref: = 388mV rms @ 1.0kHz.

Characteristics	See Note	Min.	Typ.	Max.	Unit
Static Values					
Supply Voltage		3.0	3.75	5.5	V
Supply Current		–	4.0	6.0	mA
Input Impedance (Amplifiers)		1.0	10.0	–	M Ω
Output Impedance (LP Filters)		–	2.0	–	k Ω
Output Impedance (C1, C2)		–	200	–	Ω
Output Impedance (C1, C2 Amps)		–	10.0	–	k Ω
On-Chip Xtal Oscillator					
R_{IN}		10.0	–	–	M Ω
R_{OUT}		–	10.0	–	k Ω
Inverter Gain		–	10.0	–	V/V
Gain/Bandwidth Product		–	10.0	–	MHz
Dynamic Values					
Analogue Signal Input Levels		-16.0	–	4.0	dB
SINAD	6	–	30.0	–	dB
Unwanted Modulation Products	1, 2	–	-40.0	–	dB
Carrier Breakthrough	1, 2	–	-55.0	–	dB
Baseband Breakthrough	1, 2	–	-40.0	–	dB
Carrier Frequency		–	3299	–	Hz
Analogue Output Noise	3	–	-42.0	–	dB
Analogue Output Noise	5	–	-46.0	–	dBp
Filters					
Input Lowpass Filter					
	1				
Cut-Off Frequency (-3dB)		–	3100	–	Hz
Passband Ripple (300Hz - 3kHz)		–	± 1.0	–	dB
Attenuation at 3.3kHz		–	30.0	–	dB
Attenuation at 3.6kHz		–	45.0	–	dB
Passband Gain		–	0.5	–	dB
Output Bandpass Filter					
	1, 4				
Passband Frequencies		300	–	3000	Hz
Passband Ripple		–	± 1.0	–	dB
Low Freq. Roll-Off <200Hz		12.0	–	–	dB/oct.
High Freq. – Attenuation at 3.4kHz		–	48.0	–	dB
Passband Gain		3.5	4.5	5.5	dB
Overall Modulated and De-Modulated Channel Response					
Passband Frequencies (Tx and Rx Channel)		300	–	3000	Hz
Passband Ripple		-3.0	–	2.0	dB
Low Freq. Roll-Off <250Hz		18.0	–	–	dB/oct.
High Freq. – Attenuation at 3.4kHz		–	48.0	–	dB
Passband Gain	4	–	0.5	–	dB
Distortion	1	–	3.0	–	%

Notes:

1. Measured with an audio input level of -3.0dB.
2. With respect to a single modulated (scrambling) channel.
3. Measured with a short circuit input, at any analogue output, in a 30.0kHz bandwidth.
4. With Input Amplifier gain at 0dB.
5. Measured psophometrically weighted, at any analogue output.
6. Measured in a 30kHz bandwidth.

Package Outlines

The FX118 is available in the package styles outlined below. Mechanical package diagrams and specifications are detailed in Section 10 of this document.

Pin 1 identification marking is shown on the relevant diagram and pins on all package styles number anti-clockwise when viewed from the top.

Handling Precautions

The FX118 is a CMOS LSI circuit which includes input protection. However precautions should be taken to prevent static discharges which may cause damage.

FX118DW 16-pin S.O.I.C. (D4)

FX118P 16-pin plastic DIL (P3)

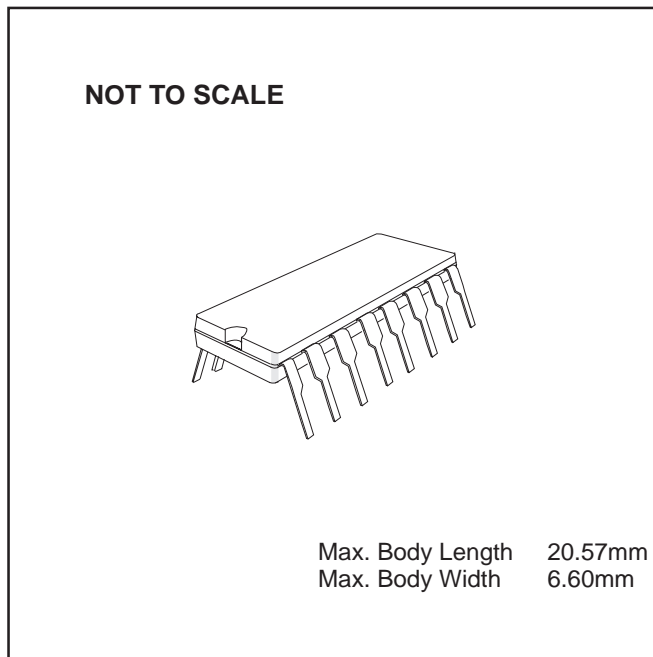
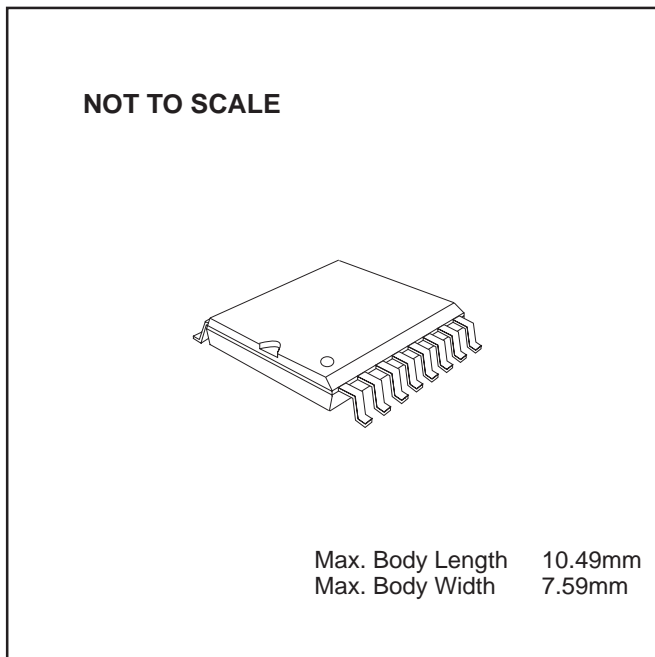

Ordering Information

FX118DW 16-pin S.O.I.C. (D4)

FX118P 16-pin plastic DIL (P3)

This datasheet has been download from:

www.datasheetcatalog.com

Datasheets for electronics components.