

KA04

ISTRUZIONI DI MONTAGGIO HKA04IP'1

Shield Ethernet per Arduino®



velleman®
projects

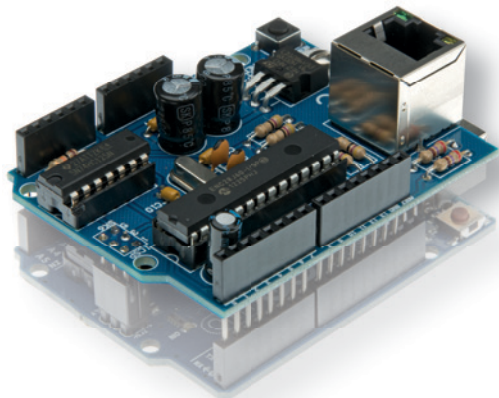

Configura la tua board Arduino™ come semplice web server o permettile di connettersi al web.

Caratteristiche

- Compatibile con Arduino Uno™, Arduino Mega™
- Basato sul chip Microchip ENC28J60
- Controller Ethernet IEEE 802.3 compatibile
- MAC & 10BASE-T PHY
- Interfaccia SPI
- Con connettore RJ45

Specifiche

- Max. frequenza di clock: 20MHz
- Buffer Trasmissione/Ricezione: 8kB
- Dimensioni: 68 x 53mm / 2,67 x 2,08"



Search product

Search Product

Navigation

- Home page
- Products
- Sales outlets
- Support
- Publications
- Jobs
- About us

News

NEW HXSD3 LED CUBE

CubeAnimator software
available for download
here!!

Posted on 04-06-12

[Read more...](#)

Velleman Projects Newsletter

Are you an electronics enthusiastic or simply interested in our kits, modules, modules and instruments?

Subscribe to our Newsletter and receive every month the latest news, new products & updates on Velleman Projects.

You will receive an e-mail. Click on the link in that e-mail to confirm your subscription.

Email:



Do you want to unsubscribe? Click on the "unsubscribe" link in the footer of the last received newsletter from Velleman Projects.



- velleman.eu
- support@velleman.eu
- panel@velleman.eu
- velleman@projects.com
- velleman@velleman.eu
- forum.velleman.eu

Advertisements



Per iscriverti alla nostra newsletter, visita il sito
www.vellemanprojects.eu

login register

en fr

view unanswered topics view active topics

it is currently 11:56:46 AM, 2012-03-20 AM

Members

100 online users (10)

Thread	Topics	Posts	Last post
Forum rules - Regolamento del Forum Read-Only / A chi è in partenza Moderatore: Vincenzo Support	2	2	Wed Dec 19, 2012 10:40 AM View last post
Forum Administration Velleman On-line Forum Development Moderatore: Vincenzo Support	1	4	Thu May 03, 2012 12:22 AM View last post
Software			
Velleman Home Automation Special section for our new Velleman Home Automation System (HMAS) Moderatore: Vincenzo Support	424	2372	Fri Sep 14, 2012 12:13 AM View last post
Kits (Building projects - Projects à construire)			
Calendar For other topics, general tips and tricks, new ideas Moderatore: Vincenzo Support	126	426	Wed Sep 05, 2012 02:37 AM View last post
Apple iOS Projects All velleman related projects, applications, velleman widgets Moderatore: Vincenzo Support	567	2463	Fri May 18, 2012 12:33 AM View last post
PC Related Projects For projects that are connected to the PC via interface cards Moderatore: Vincenzo Support	2428	6948	Fri Sep 14, 2012 02:34 AM View last post
Microcontroller programming - Coding/programming Projects How to use our advanced PIC programming terminals with Moderatore: Vincenzo Support	487	1749	Fri Sep 14, 2012 02:37 AM View last post
Home and Office All about our "home related projects from regular visitors to programmable terminals Moderatore: Vincenzo Support	266	896	Fri Sep 07, 2012 12:42 AM View last post
Home Projects Inventor/related projects. From light drivers to remote control Moderatore: Vincenzo Support	626	2282	Fri Sep 14, 2012 12:09 AM View last post

View Forum



Partecipa al nostro forum Velleman Projects



Velleman N.V.

Legen Heirweg 33

9890 Gavere

(België)

1. Montaggio (ignorare i seguenti suggerimenti, potrebbe creare delle difficoltà nella realizzazione del dispositivo!)

Si consiglia di seguire attentamente i suggerimenti di seguito riportati, per poter completare con successo il montaggio del dispositivo



1.1 Assicuratevi di possedere la giusta attrezzatura:

- Si consiglia di utilizzare un saldatore di media potenza (25 - 40 W) avente una punta da 1 mm.
- Mantenere la punta del saldatore ben pulita, tramite una spugna o un panno inumiditi con acqua. Per poter ottenere delle saldature di qualità e salvaguardare la punta, è necessario che essa sia sempre ben stagnata. Se lo stagno non dovesse aderire bene alla punta, è necessario provvedere alla pulizia di quest'ultima.
- Utilizzare stagno avente al suo interno del buon disossidante (non utilizzare paste disossidanti!).
- Per recidere i reofori dei componenti, servirsi di un tronchesino per elettronica, prestando attenzione agli occhi perché, durante il taglio, i reofori vengono proiettati a distanza.
- Utilizzare una pinza a becchi fini per piegare i reofori o per posizionare alcuni componenti.
- Munirsi di un taglierino di piccole dimensioni e di cacciaviti con misure standard.



Per alcuni progetti, è richiesto o potrebbe essere utile l'utilizzo di un comune multimetro.



1.2 Suggerimenti per il montaggio:

- Per evitare delusioni, assicurarsi che il grado di difficoltà sia compatibile con le proprie capacità ed esperienza.
- Seguire attentamente le istruzioni; leggere e capire ogni passo prima di operare.
- L'assemblaggio deve essere eseguito procedendo secondo l'ordine descritto nel manuale.
- Collocare, sul circuito stampato (PCB), ogni singolo componente come mostrato dalle figure.
- I valori riportati nello schema elettrico, possono essere soggetti a variazioni. I valori riportati in questa guida sono corretti.*
- Utilizzare le tabelle di controllo per prendere nota del proprio avanzamento.
- Leggere le note informative riguardanti la sicurezza e i servizi al cliente.

* Errori tipografici esclusi. Verificare se in allegato al presente manuale è disponibile una nota di aggiornamento.

1.3 Suggerimenti per la saldatura :

1. Montare tutti i componenti tenendo il loro corpo aderente al circuito stampato, quindi saldare con cura i relativi terminali.

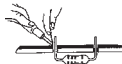

2. Assicurarsi che le saldature siano lucide e di forma conica.



3. Tagliare la parte eccedente dei reofori a filo della saldatura.



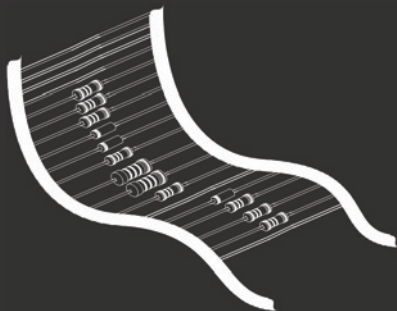

SI RACCOMANDA DI RIMUOVERNE UNO PER VOLTA

Included in
this kit



2. RESISTOR

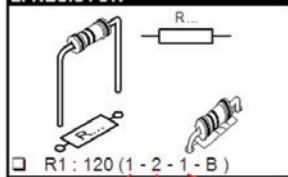

COLOUR	COLOUR NAME	1ST DIGIT/ STRIPE	2ND DIGIT/ STRIPE	3RD DIGIT/ STRIPE	MULTIPLIER STRIPE	TOLE 4TH:
	BLACK	0	0	0	x1	1%
	BROWN	1	1	1	x10	
	RED	2	2	2	x100	
	ORANGE	3	3	3	x1.000	
	YELLOW	4	4	4	x10.000	
	GREEN	5	5	5	x100.000	
	BLUE	6	6	6	x1.000.000	

**I COMPONENTI ASSIALI SONO NASTRATI
SECONDO LA SEQUENZA DI MONTAGGIO!
VERIFICARE SEMPRE IL LORO VALORE NELLA LISTA DEI
COMPONENTI!**

I MONTAGGIO

1 Resistenze



- R1: 47 (4-7-0-B)
- R2: 47 (4-7-0-B)
- R3: 18 (1-8-0-B)
- R4: 47 (4-7-0-B)
- R5: 47 (4-7-0-B)
- R6: 270 (2-7-1-B)
- R7: 270 (2-7-1-B)
- R8: 2K7 (2-7-2-B)
- R9: 10K (1-0-3-B)
- R10: 10K (1-0-3-B)
- R11: 10K (1-0-3-B)

2 Condensatori ceramici

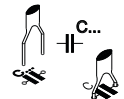
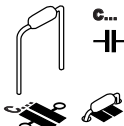

- C1: 100nF (104)
- C2: 100nF (104)
- C3: 100nF (104)
- C4: 100nF (104)
- C10: 100nF (104)

- C7: 15pF (15)
- C8: 15pF (15)

3 Quarzo



□ X1 : 25MHz

4 Pulsanti



□ SW1 : Reset

5 Regolatore di tensione



Vite M3

□ VR1 : LD1086V33

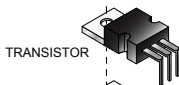

TRANSISTOR



PCB



Dado M3

6 Zoccolo IC



□ IC1 : 28p



□ IC1 : 14p

Rispettare
l'orientamento
della tacca!

7 Pin-strip M/F

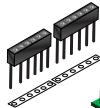

□ 2 x 6p



Non tagliare i pin
dei connettori!

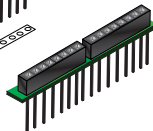
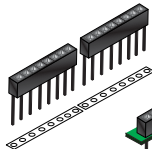

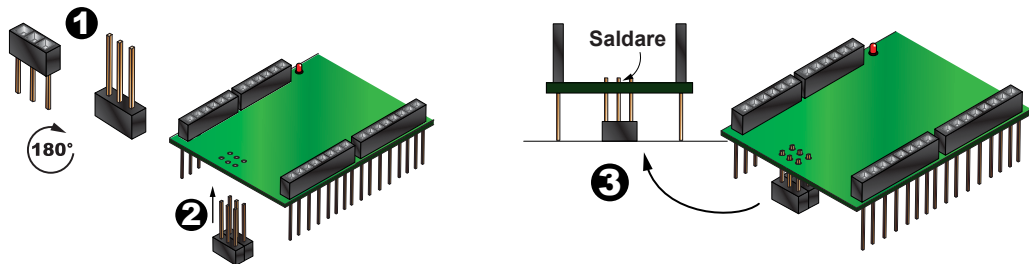

□ SK6: 2 x 3p

8 Condensatori elettrolitici



Rispettare la polarità!



- C5 : 470 μ F
- C6 : 10 μ F
- C9 : 470 μ F

9 Connettore LAN

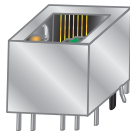

□ SK5



10 IC

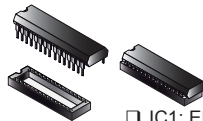

□ IC1: ENC28J60-I/SP



Rispettare l'orientamento della tacca!



□ IC2: 74HC125

II COLLEGAMENTI

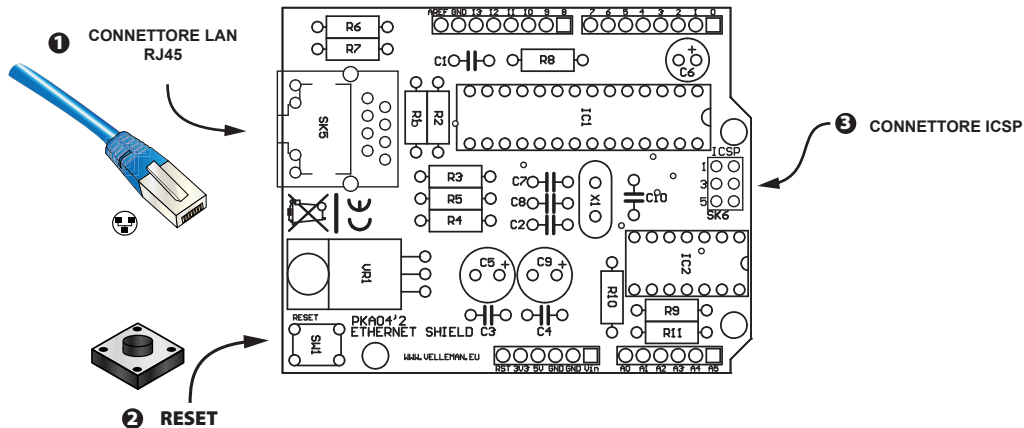

SCARICA LO SKETCH D'ESEMPIO DALLA SCHEDA DEL PRODOTTO KA04 DISPONIBILE SU WWW.VELLEMAN.BE

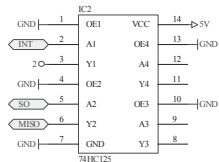
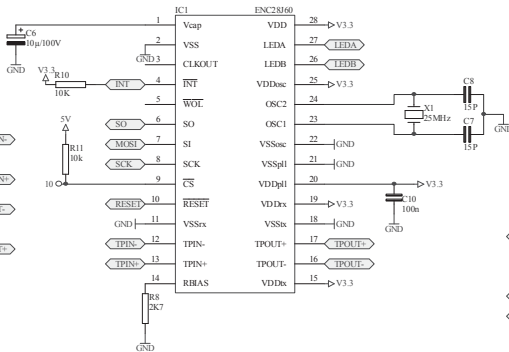
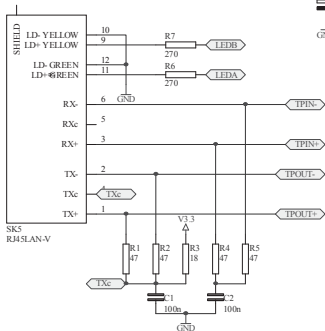
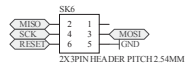
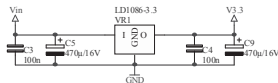
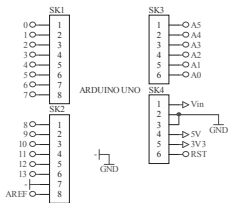

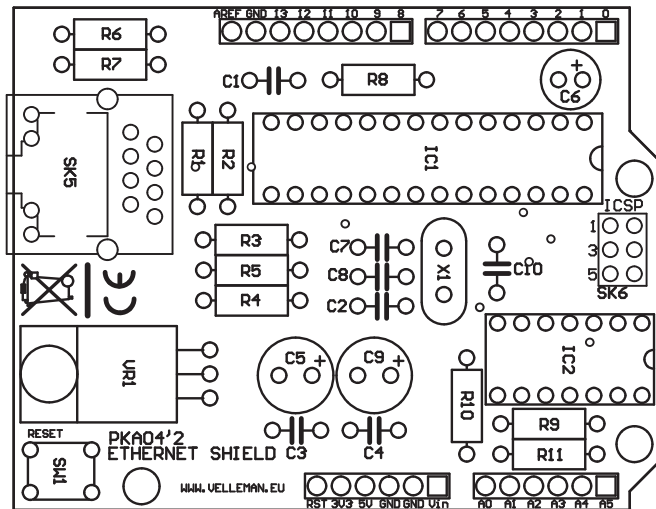

I LED e il loro utilizzo

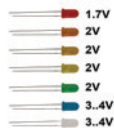

I LED presentano una caduta di tensione specifica, in funzione del tipo e del colore. Controllare la scheda tecnica per conoscere l'esatto valore di tensione e la corrente nominale!

A(+)

C(-)



Non collegare MAI i LED in parallelo

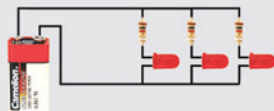
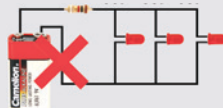

Come calcolare la resistenza da collegare in serie al LED:

Esempio: utilizzo di un LED rosso (1,7V) con una sorgente di alimentazione a 9Vdc.

Corrente richiesta dal LED per la massima luminosità: 5mA (valore indicato nel datasheet del LED)

$$\frac{\text{Alimentazione (V) - tensione LED (V)}}{\text{corrente richiesta (A)}} = \text{resistenza in serie (ohm)}$$



$$\frac{9V - 1,7V}{0,005A} = 1460 \text{ ohm}$$

valore commerciale:
1k5 ohm

Potenza resistore =
tensione ai capi della resistenza x corrente che attraversa la resistenza



$$(9V - 1,7V) \times 0,005A = 0,036W$$

una resistenza con
potenza standard di 1/4W
è più che sufficiente

LED collegati in serie:

Esempio: 3 x LED rossi (1,7V) con batteria 9V
Corrente richiesta per massima luminosità: 5mA
(valore indicato nel datasheet del LED)

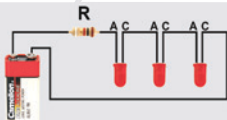

$$\frac{\text{Alimentazione (V) - (numero di LED x tensione LED (V))}}{\text{corrente richiesta (A)}} = \text{resistenza in serie (ohm)}$$



$$\frac{9V - (3 \times 1,7V)}{0,005A} = 780 \text{ ohm}$$

utilizzare una resistenza
da 820 ohm

uscite open collector

Un'uscita open collector può essere paragonata ad un interruttore che chiude verso massa quando azionato.

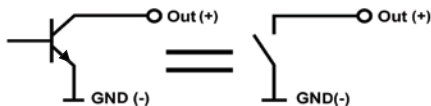

Esempio: come controllare un LED mediante un'uscita open collector

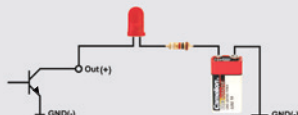



È disponibile il nuovo catalogo
Velleman Projects. Scarica la tua copia da:
www.vellemanprojects.eu



Soggetto a modifiche senza preavviso. Non siamo responsabili di eventuali
errori tipografici o di altra natura - © Velleman nv. HKA04'IP (Rev.1)
Velleman NV, Legen Heirweg 33 - 9890 Gavere.